



Unidades Condensadoras 3 - 44 HP

Modelos INBDX | INBBX | INBCX | INBEX

INB

Unidad condensadora INTERCAL
Hecho en México

D

Compresor

D: Compresor Discus Copeland
B: Compresor Pistones Bitzer
E: Compresor Pistones Carlyle

X

Exterior

X: Exterior Tiro de aire horizontal

Potencia nominal en HP

0500: 5 HP	0300: 3 HP
0650: 6.5 HP	0400: 4 HP
0750: 7.5 HP	0500: 5 HP
0800: 8 HP	0600: 6 HP
1000: 10 HP	0700: 7 HP
1200: 12 HP	0750: 7.5 HP
1500: 15 HP	0900: 9 HP
2000: 20 HP	1000: 10 HP
2200: 22 HP	1200: 12 HP
2500: 25 HP	1400: 14 HP
3000: 30 HP	1500: 15 HP
3300: 33 HP	1800: 18 HP
3500: 35 HP	2200: 22 HP
4000: 40 HP	2300: 23 HP
	2700: 27 HP
	2800: 28 HP
	3000: 30 HP
	3400: 34 HP
	4400: 44 HP

05000

M

Rango de Aplicación

M: Temp. Media/Alta
L: Temp. Baja

6

Refrigerante

6: R-404A/507

C

Voltaje

B: 208-230/1/60
C: 208-230/3/60
D: 460/3/60

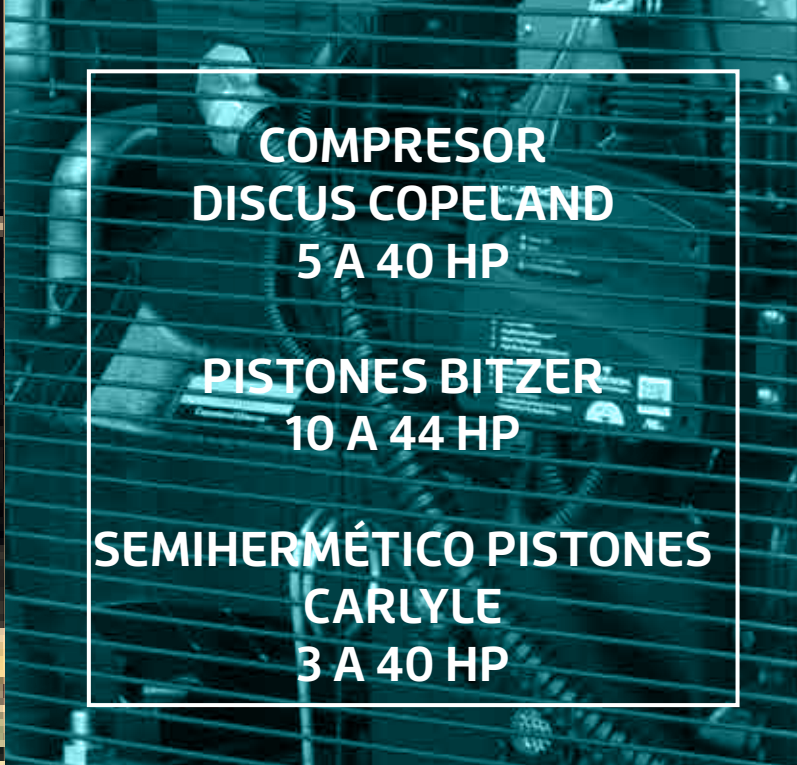

**COMPRESOR
DISCUS COPELAND
5 A 40 HP**

**PISTONES BITZER
10 A 44 HP**

**SEMIHERMÉTICO PISTONES
CARLYLE
3 A 40 HP**

- Media y Baja temperatura.
- Compresor Discus Copeland 5 a 40 HP.
- Compresor Pistones Bitzer 10 a 44 HP.
- Compresor Semihermético Pistones Carlyle 3 a 40 HP
- Recubrimiento Bohn Gold en su condensador como estándar.
- Serpentín del condensador tipo cross hatch para mayor capacidad calorífica
- Con Gabinete.
- 3 tamaños.





MODELOS

INBDX INBBX INBEX COMPRESOR SEMIHERMÉTICO RECIPROCANTE

INBCX COMPRESOR DOBLE ETAPA

R-404A/R-507/R-449A/R-448A

Modelo Unidad	H.P.	Compresor	Cant. Comp.	FLA	MCA	MOPD	Voltaje	RLA	LRA	HP	Cantidad	Consumo Motor FLA
INBDX0500M6C	5	2DC3R53KE-TFC	1	31	35.8	60	208-230/3/60	20	120	1/3	2	5.4
INBDX0500M6D	5	2DC3R53KE-TFD	1	17	19.4	30	460/3/60	9.4	60	1/3	2	3.8
INBEX0500M6C	5	06DM313	1	30	34.9	60	208-230/3/60	19.3	100	1/3	2	5.4
INBEX0500M6D	5	06DM313	1	17	19.6	30	460/3/60	9.6	50	1/3	2	3.8
INBDX0650M6C	6 1/2	2DD3R63KE-TFC	1	31	35.8	60	208-230/3/60	20	120	1/3	2	5.4
INBDX0650M6D	6 1/2	2DD3R63KE-TFD	1	17	19.4	30	460/3/60	9.4	60	1/3	2	3.8
INBEX0650M6C	6 1/2	06DM316	1	30	34.9	60	208-230/3/60	19.3	100	1/3	2	5.4
INBEX0650M6D	6 1/2	06DM316	1	17	19.6	30	460/3/60	9.6	50	1/3	2	3.8
INBDX0750M6C	7 1/2	2DL3R78KE-TFC	1	40	46.7	80	208-230/3/60	28.7	169	1/3	2	5.4
INBDX0750M6D	7 1/2	2DL3R78KE-TFD	1	20	23.4	40	460/3/60	12.6	85	1/3	2	3.8
INBDX0800M6C	8	3DA3R10ME-TFC	1	48	56.8	90	208-230/3/60	36.8	215	1/3	2	5.4
INBDX0800M6D	8	3DA3R10ME-TFD	1	26	30.0	50	460/3/60	17.9	106	1/3	2	3.8
INBEX0800M6C	8	06DA825	1	50	60.3	90	208-230/3/60	39.6	198	1/3	2	5.4
INBEX0800M6D	8	06DA825	1	27	32.4	50	460/3/60	19.8	99	1/3	2	3.8
INBDX1000M6C	10	3DB3R12ME-TFC	1	50	59.7	100	208-230/3/60	39.1	215	1/3	2	5.4
INBDX1000M6D	10	3DB3R12ME-TFD	1	26	30.0	50	460/3/60	17.9	106	1/3	2	3.8
INBEX1000M6C	10	06DA328	1	55	66.2	100	208-230/3/60	44.3	228	1/3	2	5.4
INBEX1000M6D	10	06DA328	1	30	35.2	50	460/3/60	22.1	114	1/3	2	3.8
INBBX1000M6C	10	4VES10Y-2NU	1	51	60.6	100	208-230/3/60	39.8	133	1/3	2	5.4
INBBX1000M6D	10	4VES10Y-2NU	1	24	27.5	40	460/3/60	15.9	89	1/3	2	3.8
INBDX1200M6C	12	3DF3R15ME-TFC	1	54	64.8	110	208-230/3/60	43.2	275	3/4	2	5.4
INBDX1200M6D	12	3DF3R15ME-TFD	1	29	34.1	60	460/3/60	21.2	138	3/4	2	3.8
INBBX1200M6C	12	4TES12Y-2NU	1	61	73.6	120	208-230/3/60	50.2	151	3/4	2	5.4
INBBX1200M6D	12	4TES12Y-2NU	1	33	39.0	60	460/3/60	25.1	126	3/4	2	3.8
INBDX1500M6C	15	3DS3R17ME-TFC	1	70	85.3	140	208-230/3/60	59.6	275	3/4	2	5.4
INBDX1500M6D	15	3DS3R17ME-TFD	1	37	43.9	70	460/3/60	29	138	3/4	2	3.8
INBEX1500M6C	15	06DA537	1	74	90.3	140	208-230/3/60	63.6	266	3/4	2	5.4
INBEX1500M6D	15	06DA537	1	36	43.4	70	460/3/60	28.6	120	3/4	2	3.8
INBBX1500M6C	15	4PES15Y-2NU	1	67	81.3	140	208-230/3/60	56.4	176	3/4	2	5.4
INBBX1500M6D	15	4PES15Y-2NU	1	36	42.9	70	460/3/60	28.2	147	3/4	2	3.8
INBDX2000M6C	20	4DBNR20ME-TSK	1	76	92.5	160	208-230/3/60	66	308	2	2	5
INBDX2000M6D	20	4DBNR20ME-TSK	1	39	47.3	80	460/3/60	33	154	2 1/5	2	3
INBBX2000M6C	20	4NES20Y-2NU	1	84	103.0	180	208-230/3/60	74.4	211.2	2	2	5
INBBX2000M6D	20	4NES20Y-2NU	1	43	52.5	90	460/3/60	37.2	176	2 1/5	2	3
INBBX2200M6C	22	4JE22Y-2NU	1	84	103.0	180	208-230/3/60	74.4	211.2	2	2	5
INBBX2200M6D	22	4JE22Y-2NU	1	43	52.5	90	460/3/60	37.2	176	2 1/5	2	3
INBDX2500M6C	25	4DHNR22ME-TSK	1	92	112.8	190	208-230/3/60	82.2	428	2	2	5
INBDX2500M6D	25	4DHNR22ME-TSK	1	47	57.4	100	460/3/60	41.1	214	2 1/5	2	3
INBEX2500M6C	25	06EA550	1	97	118.8	190	208-230/3/60	87	345	2	2	5
INBEX2500M6D	25	06EA550	1	50	61.0	100	460/3/60	44	173	2 1/5	2	3
INBBX2500M6C	25	4HE25Y-2NU	1	98	120.0	210	208-230/3/60	88	261.6	2	2	5
INBBX2500M6D	25	4HE25Y-2NU	1	50	61.0	110	460/3/60	44	218	2 1/5	2	3
INBDX3000M6C	30	4DJNR28ME-TSK	1	104	127.5	220	208-230/3/60	94	470	2	2	5
INBDX3000M6D	30	4DJNR28ME-TSK	1	53	64.8	110	460/3/60	47	235	2 1/5	2	3
INBEX3000M6C	30	06EA565	1	122	150.0	220	208-230/3/60	112	446	2	2	5
INBEX3000M6D	30	06EA565	1	62	76.0	110	460/3/60	56	223	2 1/5	2	3
INBBX3000M6C	30	4GE30Y-2NU	1	121	148.0	250	208-230/3/60	106.4	330	2	3	5
INBBX3000M6D	30	4GE30Y-2NU	1	62	75.5	130	460/3/60	53.2	275	2 1/5	3	3
INBDX3500M6C	35	6DHNR35ME-TSK	1	122	148.8	260	208-230/3/60	107	565	2	3	5
INBDX3500M6D	35	6DHNR35ME-TSK	1	63	75.9	130	460/3/60	53.5	283	2 1/5	3	3
INBEX3500M6C	35	06EA575	1	150	183.8	260	208-230/3/60	135	506	2	3	5
INBEX3500M6D	35	06EA575	1	77	94.0	130	460/3/60	68	253	2 1/5	3	3
INBBX3500M6C	35	6HE35Y-2NU	1	144	176.0	300	208-230/3/60	128.8	330	2	3	5
INBBX3500M6D	35	6HE35Y-2NU	1	73	89.5	150	460/3/60	64.4	275	2 1/5	3	3
INBDX4000M6C	40	6DJNR40ME-TSK	1	157	192.5	330	208-230/3/60	142	594	2	3	5
INBDX4000M6D	40	6DJNR40ME-TSK	1	80	97.8	170	460/3/60	71	297	2 1/5	3	3
INBEX4000M6C	40	06EA599	1	204	251.3	330	208-230/3/60	189	690	2	3	5
INBEX4000M6D	40	06EA599	1	104	127.8	170	460/3/60	95	345	2 1/5	3	3
INBBX4000M6C	40	6GE40Y-2NU	1	163	199.8	350	208-230/3/60	147.8	419.9	2	3	5
INBBX4000M6D	40	6GE40Y-2NU	1	83	101.4	180	460/3/60	73.9	350	2 1/5	3	3

Modelo Unidad	H.P.	Compresor	Cant. Comp.	FLA	MCA	MOPD	Voltaje	RLA	LRA	HP	Cantidad	Consumo Motor FLA
INBDX0300L6C	3	2DF3F16KE-TFC	1	25	28.8	40	208-230/3/60	14.4	102	1/3	2	5.4
INBDX0300L6D	3	2DF3F16KE-TFD	1	15	16.5	20	460/3/60	7.1	52	1/3	2	3.8
INBEX0300L6C	3	06DR316SC-1325A	1	30	34.9	40	208-230/3/60	19.3	100	1/3	2	5.4
INBEX0300L6D	3	06DR316SC-1365A	1	17	19.6	20	460/3/60	9.6	50	1/3	2	3.8
INBDX0400L6C	4	2DL3F20KE-TFC	1	34	40.3	60	208-230/3/60	23.6	161	1/3	2	5.4
INBDX0400L6D	4	2DL3F20KE-TFD	1	17	19.1	30	460/3/60	9.2	60	1/3	2	3.8
INBEX0400L6C	4	06DR718SD-1325A	1	30	34.9	60	208-230/3/60	19.3	100	1/3	2	5.4
INBEX0400L6D	4	06DR718SD-1365A	1	17	19.6	30	460/3/60	9.6	50	1/3	2	3.8
INBDX0500L6C	5	2DB3F25KE-TFC	1	36	42.4	70	208-230/3/60	25.3	161	1/3	2	5.4
INBDX0500L6D	5	2DB3F25KE-TFD	1	20	22.5	30	460/3/60	11.9	80	1/3	2	3.8
INBEX0500L6C	5	06DR820SD-1325A	1	42	50.1	70	208-230/3/60	31.4	160	1/3	2	5.4
INBEX0500L6D	5	06DR820SD-1365A	1	23	27.2	30	460/3/60	15.7	80	1/3	2	3.8
INBDX0600L6C	6	3DA3F28KE-TFC	1	35	40.8	60	208-230/3/60	24	150	1/3	2	5.4
INBDX0600L6D	6	3DA3F28KE-TFD	1	18	21.1	30	460/3/60	10.8	77	1/3	2	3.8
INBEX0600L6C	6	06DR725SD-1325A	1	42	50.1	70	208-230/3/60	31.4	160	1/3	2	5.4
INBEX0600L6D	6	06DR725SD-1365A	1	23	27.2	40	460/3/60	15.7	80	1/3	2	3.8
INBDX0750L6C	7 1/2	3DB3F33KE-TFC	1	38	45.3	70	208-230/3/60	27.6	161	1/3	2	5.4
INBDX0750L6D	7 1/2	3DB3F33KE-TFD	1	22	25.2	40	460/3/60	14.1	83	1/3	2	3.8
INBEX0750L6C	7 1/2	06DR228SD-1325A	1	50	60.3	70	208-230/3/60	39.6	198	1/3	2	5.4
INBEX0750L6D	7 1/2	06DR228SD-1365A	1	27	32.4	40	460/3/60	19.8	99	1/3	2	3.8
INBDX0900L6C	9	3DF3F40KE-TFC	1	44	52.3	90	208-230/3/60	33.2	215	1/3	2	5.4
INBDX0900L6D	9	3DF3F40KE-TFD	1	23	26.4	40	460/3/60	15	106	1/3	2	3.8
INBDX1000L6C	10	3DS3F46KE-TFC	1	48	57.3	90	208-230/3/60	37.2	215	1/3	2	5.4
INBDX1000L6D	10	3DS3F46KE-TFD	1	24	28.5	50	460/3/60	16.7	106	1/3	2	3.8
INBEX1000L6C	10	06DR337SD-1325A	1	55	66.2	90	208-230/3/60	44.3	228	3/4	2	5.4
INBEX1000L6D	10	06DR337SD-1365A	1	30	35.2	50	460/3/60	22.1	114	3/4	2	3.8
INBDX1200L6C	10	4DBNF54KE-TSK	1	57	68.3	110	208-230/3/60	46	220	3/4	2	5.4
INBDX1200L6D	10	4DBNF54KE-TSK	1	31	36.4	50	460/3/60	23	110	3/4	2	3.8
INBBX1200L6C	12	4PES12Y-2NU	1	56	67.6	110	208-230/3/60	45.4	133	3/4	2	5.4
INBBX1200L6D	12	4PES12Y-2NU	1	30	36.0	50	460/3/60	22.7	111	3/4	2	3.8
INBEX1200L6C	12	06DR541SD-1125A	1	68	82.2	110	208-230/3/60	57.1	266	3/4	2	5.4
INBEX1200L6D	12	06DR541SD-1065A	1	33	39.6	50	460/3/60	25.6	120	3/4	2	3.8
INBBX1400L6C	14	4NES14Y-2NU	1	64	77.3	130	208-230/3/60	53.2	151	3/4	2	5.4
INBBX1400L6D	14	4NES14Y-2NU	1	34	40.9	70	460/3/60	26.6	126	3/4	2	3.8
INBDX1500L6C	15	4DHNF63KE-TSK	1	58	69.8	120	208-230/3/60	47.2	278	3/4	2	5.4
INBDX1500L6D	15	4DHNF63KE-TSK	1	31	37.1	60	460/3/60	23.6	139	3/4	2	3.8
INBBX1800L6C	18	4HE18Y-2NU	1	84	102.6	180	208-230/3/60	73.4	211.2	3/4	2	5.4
INBBX1800L6D	18	4HE18Y-2NU	1	44	53.5	90	460/3/60	36.7	176	3/4	2	3.8
INBDX2200L6C	22	4DJNF76KE-TSK	1	68	82.1	140	208-230/3/60	57.7	374	2	2	5
INBDX2200L6D	22	4DJNF76KE-TSK	1	35	42.0	70	460/3/60	28.8	187	2 1/5	2	3
INBBX2300L6C	23	4GE23Y-2NU	1	98	119.8	210	208-230/3/60	87.8	211.1	2	2	5
INBBX2300L6D	23	4GE23Y-2NU	1	50	60.9	100	460/3/60	43.9	90	2 1/5	2	3
INBDX2700L6C	27	6DHNF93KE-TSK	1	82	100.5	170	208-230/3/60	72.4	450	2	2	5
INBDX2700L6D	27	6DHNF93KE-TSK	1	42	51.3	90	460/3/60	36.2	225	2 1/5	2	3
INBEX2700L6C	20	06ER4753SA	1	100	122.5	170	208-230/3/60	90	345	2	2	5
INBEX2700L6D	20	06ER4753SA	1	51	62.3	90	460/3/60	45	173	2 1/5	2	3
INBBX2800L6C	28	4FE28Y-2NU	1	116	142.0	250	208-230/3/60	105.6	294	2	2	5
INBBX2800L6D	28	4FE28Y-2NU	1	59	72.0	120	460/3/60	52.8	245	2 1/5	2	3
INBDX3000L6C	30	6DJNF11ME-TSK	1	95	116.3	200	208-230/3/60	85.8	470	2 1/5	3	3
INBDX3000L6D	30	6DJNF11ME-TSK	1	58	68.6	110	460/3/60	42.9	235	2	3	5
INBEX3000L6C	30	06ER3993SA	1	144	177.8	200	208-230/3/60	135	506	2 1/5	3	3
INBEX3000L6D	30	06ER3993SA	1	83	100.0	120	460/3/60	68	253	2	3	5
INBBX3400L6C	34	6GE34Y-2NU	1	140	172.8	300	208-230/3/60	131	294	2 1/5	3	3
INBBX3400L6D	34	6GE34Y-2NU	1	81	96.9	160	460/3/60	65.5	132	2	3	5
INBBX4400L6C	44	6FE44Y-2NU	1	175	217.0	380	208-230/3/60	166.4	419.9	2 1/5	3	3
INBBX4400L6D	44	6FE44Y-2NU	1	98	119.0	200	460/3/60	83.2	425	2	3	5

Modelo Unidad	Desplazamiento Vol.	Flujo Másico	Conexiones (DI) pulg		Recibidor Cap al 90%		Largo		Ancho		Alto		Peso	
	in3/rev	CFM	Succion	Líquido	Lbs	Kgs	cm	pulg.	cm	pulg.	cm	pulg.	Kg	Lbs
INBDX0500M6C	11.78	12	1 3/8	1/2	24.75	11.22	155.5	61.2	90.40	35.6	99.8	39.3	433	955.4
INBDX0500M6D	11.78	12	1 3/8	1/2	24.75	11.22	155.5	61.2	90.40	35.6	99.8	39.3	433	955.4
INBEX0500M6C	12.85	13	1 3/8	1/2	24.75	11.22	155.5	61.2	90.40	35.6	99.8	39.3	433	955.4
INBEX0500M6D	12.85	13	1 3/8	1/2	24.75	11.22	155.5	61.2	90.40	35.6	99.8	39.3	433	955.4
INBDX0650M6C	13.55	14	1 3/8	5/8	67.5	30.62	155.5	61.2	90.40	35.6	99.8	39.3	441	971.4
INBDX0650M6D	13.55	14	1 3/8	5/8	67.5	30.62	155.5	61.2	90.40	35.6	99.8	39.3	441	971.4
INBEX0650M6C	15.72	16	1 3/8	5/8	67.5	30.62	155.5	61.2	90.40	35.6	99.8	39.3	441	971.4
INBEX0650M6D	15.72	16	1 3/8	5/8	67.5	30.62	155.5	61.2	90.40	35.6	99.8	39.3	441	971.4
INBDX0750M6C	16.59	17	1 3/8	5/8	67.5	30.62	155.5	61.2	90.40	35.6	99.8	39.3	441	971.4
INBDX0750M6D	16.59	17	1 3/8	5/8	67.5	30.62	155.5	61.2	90.40	35.6	99.8	39.3	441	971.4
INBDX0800M6C	22.6	23	1 3/8	5/8	67.5	30.62	155.5	61.2	90.40	35.6	99.8	39.3	468	1031.5
INBDX0800M6D	22.6	23	1 3/8	5/8	67.5	30.62	155.5	61.2	90.40	35.6	99.8	39.3	468	1031.5
INBEX0800M6C	23.63	24	1 3/8	5/8	67.5	30.62	155.5	61.2	90.40	35.6	99.8	39.3	468	1031.5
INBEX0800M6D	23.63	24	1 3/8	5/8	67.5	30.62	155.5	61.2	90.40	35.6	99.8	39.3	468	1031.5
INBDX1000M6C	26.69	27	1 3/8	5/8	67.5	30.62	155.5	61.2	90.40	35.6	99.8	39.3	468	1031.5
INBDX1000M6D	26.69	27	1 3/8	5/8	67.5	30.62	155.5	61.2	90.40	35.6	99.8	39.3	468	1031.5
INBEX1000M6C	27.68	28	1 3/8	5/8	67.5	30.62	155.5	61.2	90.40	35.6	99.8	39.3	468	1031.5
INBEX1000M6D	27.68	28	1 3/8	5/8	67.5	30.62	155.5	61.2	90.40	35.6	99.8	39.3	468	1031.5
INBBX1000M6C	24.41	25	1 1/8	5/8	67.5	30.62	155.5	61.2	90.40	35.6	99.8	39.3	432	952.6
INBBX1000M6D	24.41	25	1 1/8	5/8	67.5	30.62	155.5	61.2	90.40	35.6	99.8	39.3	432	952.6
INBDX1200M6C	31.43	32	1 3/8	5/8	67.5	30.62	190.6	95	106.90	45.6	123.8	48.8	568	1252.0
INBDX1200M6D	31.43	32	1 3/8	5/8	67.5	30.62	190.6	95	106.90	45.6	123.8	48.8	568	1252.0
INBBX1200M6C	28.87	29	1 3/8	7/8	67.5	30.62	190.6	95	106.90	45.6	123.8	48.8	534	1177.5
INBBX1200M6D	28.87	29	1 3/8	7/8	67.5	30.62	190.6	95	106.90	45.6	123.8	48.8	534	1177.5
INBDX1500M6C	35.07	35	1 5/8	7/8	67.5	30.62	190.6	95	106.90	45.6	123.8	48.8	568	1252.0
INBDX1500M6D	35.07	35	1 5/8	7/8	67.5	30.62	190.6	95	106.90	45.6	123.8	48.8	568	1252.0
INBEX1500M6C	36.68	37	1 5/8	7/8	67.5	30.62	190.6	95	106.90	45.6	123.8	48.8	568	1252.0
INBEX1500M6D	36.68	37	1 5/8	7/8	67.5	30.62	190.6	95	106.90	45.6	123.8	48.8	568	1252.0
INBBX1500M6C	33.97	34	1 5/8	7/8	67.5	30.62	190.6	95	106.90	45.6	123.8	48.8	532	1173.1
INBBX1500M6D	33.97	34	1 5/8	7/8	67.5	30.62	190.6	95	106.90	45.6	123.8	48.8	532	1173.1
INBDX2000M6C	43.39	46	2 1/8	7/8	150	68	292.7	115.2	122.60	48.3	123.5	48.6	994	2191.5
INBDX2000M6D	43.39	46	2 1/8	7/8	150	68	292.7	115.2	122.60	48.3	123.5	48.6	994	2191.5
INBBX2000M6C	39.49	40	1 5/8	7/8	150	68	292.7	115.2	122.60	48.3	123.5	48.6	940	2071.8
INBBX2000M6D	39.49	40	1 5/8	7/8	150	68	292.7	115.2	122.60	48.3	123.5	48.6	940	2071.8
INBBX2200M6C	44.68	45	1 5/8	1 1/8	150	68	292.7	115.2	122.60	48.3	123.5	48.6	980	2160.0
INBBX2200M6D	44.68	45	1 5/8	1 1/8	150	68	292.7	115.2	122.60	48.3	123.5	48.6	980	2160.0
INBDX2500M6C	50.24	50	2 1/8	1 1/8	150	68	292.7	115.2	122.60	48.3	123.5	48.6	994	2191.5
INBDX2500M6D	50.24	50	2 1/8	1 1/8	150	68	292.7	115.2	122.60	48.3	123.5	48.6	994	2191.5
INBEX2500M6C	49.72	50	2 1/8	1 1/8	150	68	292.7	115.2	122.60	48.3	123.5	48.6	994	2191.5
INBEX2500M6D	49.72	50	2 1/8	1 1/8	150	68	292.7	115.2	122.60	48.3	123.5	48.6	994	2191.5
INBBX2500M6C	51.93	52	2 1/8	1 1/8	150	68	292.7	115.2	122.60	48.3	123.5	48.6	993	2188.7
INBBX2500M6D	51.93	52	2 1/8	1 1/8	150	68	292.7	115.2	122.60	48.3	123.5	48.6	993	2188.7
INBDX3000M6C	61.52	62	2 1/8	1 1/8	150	68	292.7	115.2	122.60	48.3	123.5	48.6	994	2191.5
INBDX3000M6D	61.52	62	2 1/8	1 1/8	150	68	292.7	115.2	122.60	48.3	123.5	48.6	994	2191.5
INBEX3000M6C	67.52	68	2 1/8	1 1/8	150	68	292.7	115.2	122.60	48.3	123.5	48.6	1,138	2508.2
INBEX3000M6D	67.52	68	2 1/8	1 1/8	150	68	292.7	115.2	122.60	48.3	123.5	48.6	1,138	2508.2
INBBX3000M6C	59.33	60	2 1/8	1 1/8	150	68	292.7	115.2	122.60	48.3	123.5	48.6	1,138	2508.2
INBBX3000M6D	59.33	60	2 1/8	1 1/8	150	68	292.7	115.2	122.60	48.3	123.5	48.6	1,138	2508.2
INBDX3500M6C	73.24	74	2 1/8	1 1/8	150	68	292.7	115.2	122.60	48.3	123.5	48.6	1,181	2604.5
INBDX3500M6D	73.24	74	2 1/8	1 1/8	150	68	292.7	115.2	122.60	48.3	123.5	48.6	1,181	2604.5
INBEX3500M6C	74.54	75	2 1/8	1 1/8	150	68	292.7	115.2	122.60	48.3	123.5	48.6	1,181	2604.5
INBEX3500M6D	74.54	75	2 1/8	1 1/8	150	68	292.7	115.2	122.60	48.3	123.5	48.6	1,181	2604.5
INBBX3500M6C	77.9	78	2 1/8	1 1/8	150	68	292.7	115.2	122.60	48.3	123.5	48.6	1,167	2572.1
INBBX3500M6D	77.9	78	2 1/8	1 1/8	150	68	292.7	115.2	122.60	48.3	123.5	48.6	1,167	2572.1
INBDX4000M6C	89.2	90	2 1/8	1 1/8	150	68	292.7	115.2	122.60	48.3	123.5	48.6	1,188	2619.6
INBDX4000M6D	89.2	90	2 1/8	1 1/8	150	68	292.7	115.2	122.60	48.3	123.5	48.6	1,188	2619.6
INBEX4000M6C	97.87	99	2 1/8	1 1/8	150	68	292.7	115.2	122.60	48.3	123.5	48.6	1,188	2619.6
INBEX4000M6D	97.87	99	2 1/8	1 1/8	150	68	292.7	115.2	122.60	48.3	123.5	48.6	1,188	2619.6
INBBX4000M6C	88.99	90	2 1/8	1 1/8	150	68	292.7	115.2	122.60	48.3	123.5	48.6	1,170	2578.7
INBBX4000M6D	88.99	90	2 1/8	1 1/8	150	68	292.7	115.2	122.60	48.3	123.5	48.6	1,170	2578.7

Modelo Unidad	Desplazamiento Vol.	Flujo Másico	Conexiones (DI) pulg		Recibidor Cap al 90%		Largo		Ancho		Alto		Peso	
	in3/rev	CFM	Succion	Líquido	Lbs	Kgs	cm	pulg.	cm	pulg.	cm	pulg.	Kg	Lbs
INBDX0300L6C	14.99	15	13/8	1/2	15.51	7.03	119.8	47.1	78.10	30.7	72.8	28.7	230	507.2
INBDX0300L6D	14.99	15	13/8	1/2	15.51	7.03	119.8	47.1	78.10	30.7	72.8	28.7	230	507.2
INBEX0300L6C	15.72	16	13/8	1/2	24.75	11.22	155.5	61.2	90.40	35.6	99.8	39.3	230	507.2
INBEX0300L6D	15.72	16	13/8	1/2	24.75	11.22	155.5	61.2	90.40	35.6	99.8	39.3	230	507.2
INBDX0400L6C	16.59	17	13/8	1/2	24.75	11.22	119.8	47.1	78.10	30.7	72.8	28.7	230	507.2
INBDX0400L6D	16.59	17	13/8	1/2	24.75	11.22	119.8	47.1	78.10	30.7	72.8	28.7	230	507.2
INBEX0400L6C	18.09	18	13/8	1/2	24.75	11.22	155.5	61.2	90.40	35.6	99.8	39.3	441	972.5
INBEX0400L6D	18.09	18	13/8	1/2	24.75	11.22	155.5	61.2	90.40	35.6	99.8	39.3	441	972.5
INBDX0500L6C	19.67	20	13/8	1/2	24.75	11.22	155.5	61.2	90.40	35.6	99.8	39.3	441	972.5
INBDX0500L6D	19.67	20	13/8	1/2	24.75	11.22	155.5	61.2	90.40	35.6	99.8	39.3	441	972.5
INBEX0500L6C	19.77	20	13/8	1/2	24.75	11.22	155.5	61.2	90.40	35.6	99.8	39.3	441	972.5
INBEX0500L6D	19.77	20	13/8	1/2	24.75	11.22	155.5	61.2	90.40	35.6	99.8	39.3	441	972.5
INBDX0600L6C	22.6	23	13/8	1/2	24.75	11.22	155.5	61.2	90.40	35.6	99.8	39.3	441	972.5
INBDX0600L6D	22.6	23	13/8	1/2	24.75	11.22	155.5	61.2	90.40	35.6	99.8	39.3	441	972.5
INBEX0600L6C	23.63	24	13/8	1/2	24.75	11.22	155.5	61.2	90.40	35.6	99.8	39.3	441	972.5
INBEX0600L6D	23.63	24	13/8	1/2	24.75	11.22	155.5	61.2	90.40	35.6	99.8	39.3	441	972.5
INBDX0750L6C	26.69	27	13/8	1/2	67.5	30.62	155.5	61.2	90.40	35.6	99.8	39.3	470	1036.4
INBDX0750L6D	26.69	27	13/8	1/2	67.5	30.62	155.5	61.2	90.40	35.6	99.8	39.3	470	1036.4
INBEX0750L6C	24.42	25	13/8	1/2	67.5	30.62	155.5	61.2	90.40	35.6	99.8	39.3	470	1036.4
INBEX0750L6D	24.42	25	13/8	1/2	67.5	30.62	155.5	61.2	90.40	35.6	99.8	39.3	470	1036.4
INBDX0900L6C	31.43	32	13/8	5/8	67.5	30.62	155.5	61.2	90.40	35.6	99.8	39.3	470	1036.4
INBDX0900L6D	31.43	32	13/8	5/8	67.5	30.62	155.5	61.2	90.40	35.6	99.8	39.3	470	1036.4
INBDX1000L6C	35.07	35	13/8	5/8	67.5	30.62	155.5	61.2	90.40	35.6	99.8	39.3	470	1036.4
INBDX1000L6D	35.07	35	13/8	5/8	67.5	30.62	155.5	61.2	90.40	35.6	99.8	39.3	470	1036.4
INBEX1000L6C	36.68	37	13/8	5/8	67.5	30.62	155.5	61.2	90.40	35.6	99.8	39.3	470	1036.4
INBEX1000L6D	36.68	37	13/8	5/8	67.5	30.62	155.5	61.2	90.40	35.6	99.8	39.3	470	1036.4
INBDX1200L6C	43.39	44	15/8	7/8	67.5	30.62	190.6	95.0	106.90	45.6	123.8	48.8	568	1252.0
INBDX1200L6D	43.39	44	15/8	7/8	67.5	30.62	190.6	95.0	106.90	45.6	123.8	48.8	568	1252.0
INBBX1200L6C	33.97	34	13/8	7/8	67.5	30.62	190.6	95.0	106.90	45.6	123.8	48.8	534	1177.5
INBBX1200L6D	33.97	34	13/8	7/8	67.5	30.62	190.6	95.0	106.90	45.6	123.8	48.8	534	1177.5
INBEX1200L6C	40.96	41	15/8	7/8	67.5	30.62	190.6	95.0	106.90	45.6	123.8	48.8	540	1190.7
INBEX1200L6D	40.96	41	15/8	7/8	67.5	30.62	190.6	95.0	106.90	45.6	123.8	48.8	540	1190.7
INBBX1400L6C	39.49	40	15/8	7/8	67.5	30.62	190.6	95.0	106.90	45.6	123.8	48.8	568	1252.0
INBBX1400L6D	39.49	40	15/8	7/8	67.5	30.62	190.6	95.0	106.90	45.6	123.8	48.8	568	1252.0
INBDX1500L6C	50.24	50	15/8	7/8	67.5	30.62	190.6	95.0	106.90	45.6	123.8	48.8	532	1173.1
INBDX1500L6D	50.24	50	15/8	7/8	67.5	30.62	190.6	95.0	106.90	45.6	123.8	48.8	532	1173.1
INBBX1800L6C	51.93	52	15/8	7/8	67.5	30.62	190.6	95.0	106.90	45.6	123.8	48.8	532	1173.1
INBBX1800L6D	51.93	52	15/8	7/8	67.5	30.62	190.6	95.0	106.90	45.6	123.8	48.8	532	1173.1
INBDX2200L6C	59.47	60	2 1/8	7/8	150	68	292.7	115.2	122.60	48.3	123.5	48.6	995	2194.0
INBDX2200L6D	59.47	60	2 1/8	7/8	150	68	292.7	115.2	122.60	48.3	123.5	48.6	995	2194.0
INBBX2300L6C	59.33	60	2 1/8	7/8	150	68	292.7	115.2	122.60	48.3	123.5	48.6	985	2172.0
INBBX2300L6D	59.33	60	2 1/8	7/8	150	68	292.7	115.2	122.60	48.3	123.5	48.6	985	2172.0
INBDX2700L6C	74.68	75	2 1/8	7/8	150	68	292.7	115.2	122.60	48.3	123.5	48.6	1,040	2293.2
INBDX2700L6D	74.68	75	2 1/8	7/8	150	68	292.7	115.2	122.60	48.3	123.5	48.6	1,040	2293.2
INBEX2700L6C	74.54	75	2 1/8	7/8	150	68	292.7	115.2	122.60	48.3	123.5	48.6	1,040	2293.2
INBEX2700L6D	74.54	75	2 1/8	7/8	150	68	292.7	115.2	122.60	48.3	123.5	48.6	1,040	2293.2
INBBX2800L6C	70.68	71	2 1/8	1 1/8	150	68	292.7	115.2	122.60	48.3	123.5	48.6	997	2198.4
INBBX2800L6D	70.68	71	2 1/8	1 1/8	150	68	292.7	115.2	122.60	48.3	123.5	48.6	997	2198.4
INBDX3000L6C	89.2	90	2 1/8	1 1/8	150	68	292.7	115.2	122.60	48.3	123.5	48.6	1,040	2293.2
INBDX3000L6D	89.2	90	2 1/8	1 1/8	150	68	292.7	115.2	122.60	48.3	123.5	48.6	1,040	2293.2
INBEX3000L6C	97.87	99	2 1/8	1 1/8	150	68	292.7	115.2	122.60	48.3	123.5	48.6	1,040	2293.2
INBEX3000L6D	97.87	99	2 1/8	1 1/8	150	68	292.7	115.2	122.60	48.3	123.5	48.6	1,040	2293.2
INBBX3400L6C	88.99	90	2 1/8	1 1/8	150	68	292.7	115.2	122.60	48.3	123.5	48.6	1,040	2293.2
INBBX3400L6D	88.99	90	2 1/8	1 1/8	150	68	292.7	115.2	122.60	48.3	123.5	48.6	1,040	2293.2
INBBX4400L6C	106.69	108	2 1/8	1 1/8	150	68	292.7	115.2	122.60	48.3	123.5	48.6	1,040	2293.2
INBBX4400L6D	106.69	108	2 1/8	1 1/8	150	68	292.7	115.2	122.60	48.3	123.5	48.6	1,040	2293.2

INBBX

R404A

ESPECIFICACIONES

Modelo	Compresor	H.P	TSC		TSE °F C=Capacidad Btu's/h P=Potencia watts A=Corriente Amps.											
					-10	-5	0	5	10	15	20	25	30	35	40	45
INBDX0500M6C	2DC3R53KE-TFC	5	130	C	13,574	15,661	18,004	20,615	23,506	26,688	30,174	33,975	38,102	42,568	47,384	52,562
				P	3,241	3,461	3,692	3,931	4,174	4,416	4,653	4,881	5,096	5,295	5,472	5,624
				A	12.1	12.5	13.0	13.5	14.0	14.6	15.1	15.7	16.2	16.7	17.1	17.5
			120	C	15,666	18,026	20,687	23,661	26,959	30,595	34,578	38,921	43,636	48,735	54,229	60,130
				P	3,195	3,400	3,614	3,833	4,052	4,267	4,474	4,670	4,849	5,008	5,143	5,250
				A	12.0	12.4	12.8	13.3	13.8	14.3	14.7	15.2	15.6	16.0	16.3	16.6
		110	C	17,785	20,430	23,422	26,771	30,490	34,591	39,085	43,984	49,299	55,044	61,228	67,865	
			P	3,125	3,315	3,510	3,707	3,900	4,087	4,263	4,424	4,566	4,684	4,775	4,835	
			A	11.9	12.2	12.6	13.0	13.5	13.9	14.3	14.6	15.0	15.3	15.5	15.6	
		100	C	19,923	22,866	26,201	29,939	34,091	38,670	43,687	49,155	55,084	61,487	68,375	75,760	
			P	3,031	3,203	3,378	3,551	3,717	3,874	4,017	4,142	4,244	4,321	4,366	4,377	
			A	11.7	12.0	12.4	12.7	13.1	13.4	13.8	14.0	14.3	14.5	14.6	14.6	
INBDX0650M6C	2DD3R63KE-TFC	6.5	130	C	17,446	19,693	22,318	25,323	28,707	32,470	36,611	41,130	46,027	51,302	56,955	62,985
				P	3,955	4,176	4,420	4,681	4,952	5,229	5,504	5,773	6,030	6,268	6,482	6,666
				A	13.6	14.1	14.6	15.2	15.8	16.5	17.1	17.8	18.4	19.0	19.5	20.0
			120	C	19,700	22,356	25,432	28,928	32,845	37,181	41,937	47,113	52,707	58,721	65,153	72,003
				P	3,856	4,069	4,299	4,542	4,791	5,040	5,284	5,516	5,732	5,924	6,087	6,216
				A	13.4	13.8	14.3	14.9	15.4	16.0	16.5	17.1	17.6	18.1	18.5	18.8
		110	C	22,021	25,064	28,569	32,536	36,963	41,852	47,201	53,011	59,282	66,012	73,202	80,852	
			P	3,728	3,929	4,144	4,365	4,589	4,808	5,017	5,210	5,381	5,524	5,633	5,704	
			A	13.1	13.5	14.0	14.4	14.9	15.4	15.9	16.3	16.7	17.1	17.3	17.5	
		100	C	24,447	27,857	31,769	36,184	41,101	46,520	52,441	58,864	65,788	73,213	81,140	89,567	
			P	3,580	3,767	3,962	4,160	4,355	4,541	4,712	4,862	4,986	5,077	5,130	5,139	
			A	12.8	13.2	13.6	14.0	14.4	14.8	15.2	15.5	15.8	16.0	16.2	16.2	
INBDX0750M6C	2DL3R78KE-TFC	7.5	130	C	21,706	24,811	28,242	32,022	36,172	40,716	45,675	51,072	56,929	63,268	70,111	77,481
				P	4,903	5,215	5,541	5,876	6,215	6,554	6,888	7,214	7,526	7,819	8,091	8,336
				A	17.3	18.0	18.7	19.4	20.2	20.9	21.7	22.5	23.2	24.0	24.7	25.3
			120	C	24,697	28,158	32,013	36,282	40,988	46,153	51,800	57,950	64,626	71,851	79,645	88,033
				P	4,791	5,081	5,381	5,686	5,991	6,292	6,584	6,863	7,125	7,365	7,578	7,761
				A	17.1	17.7	18.3	19.0	19.7	20.4	21.0	21.7	22.3	22.9	23.5	24.0
		110	C	27,686	31,506	35,785	40,545	45,807	51,595	57,931	64,836	72,333	80,444	89,192	98,598	
			P	4,646	4,913	5,186	5,459	5,729	5,991	6,240	6,472	6,682	6,867	7,021	7,139	
			A	16.8	17.3	17.9	18.5	19.1	19.7	20.2	20.8	21.3	21.7	22.1	22.5	
		100	C	30,697	34,877	39,582	44,833	50,654	57,066	64,091	71,752	80,071	89,071	98,773	109,199	
			P	4,468	4,711	4,955	5,196	5,430	5,651	5,855	6,039	6,197	6,325	6,418	6,472	
			A	16.4	16.9	17.4	17.9	18.5	18.9	19.4	19.8	20.2	20.5	20.7	20.9	
INBDX0800M6C	3DA3R10ME-TFC	8	130	C	31,294	35,851	40,690	45,857	51,394	57,345	63,754	70,665	78,122	86,168	94,847	104,203
				P	6,901	7,380	7,850	8,309	8,753	9,181	9,590	9,976	10,339	10,674	10,979	11,253
				A	23.3	24.4	25.4	26.5	27.5	28.5	29.5	30.5	31.3	32.2	32.9	33.6
			120	C	35,476	40,288	45,499	51,153	57,294	63,965	71,210	79,073	87,598	96,828	106,807	117,579
				P	6,685	7,125	7,554	7,968	8,364	8,741	9,095	9,424	9,726	9,998	10,237	10,441
				A	22.8	23.8	24.8	25.7	26.6	27.5	28.3	29.1	29.9	30.5	31.1	31.6
		110	C	38,993	44,183	49,888	56,152	63,019	70,532	78,736	87,673	97,388	107,925	119,326	131,637	
			P	6,438	6,837	7,222	7,588	7,934	8,257	8,555	8,824	9,063	9,269	9,439	9,571	
			A	22.3	23.2	24.0	24.9	25.6	26.4	27.1	27.7	28.3	28.8	29.2	29.5	
		100	C	42,383	48,074	54,396	61,392	69,108	77,585	86,869	97,003	108,031	119,996	132,943	146,914	
			P	6,167	6,522	6,860	7,176	7,469	7,736	7,975	8,182	8,356	8,493	8,592	8,649	
			A	21.7	22.5	23.2	23.9	24.6	25.2	25.7	26.2	26.6	27.0	27.2	27.3	

Modelo	Compresor	H.P	TSC		TSE °F C=Capacidad Btu's/h P=Potencia watts A=Corriente Amps.											
					-10	-5	0	5	10	15	20	25	30	35	40	45
INBDX1000M6C	3DB3R12ME-TFC	10	130	C	37,075	42,617	48,400	54,500	60,991	67,947	75,443	83,553	92,351	101,913	112,311	123,622
				P	8,336	8,924	9,500	10,063	10,608	11,133	11,636	12,113	12,563	12,982	13,368	13,718
				A	26.6	28.0	29.4	30.8	32.1	33.5	34.8	36.0	37.2	38.3	39.3	40.1
			120	C	42,030	48,012	54,350	61,119	68,393	76,246	84,753	93,988	104,026	114,940	126,806	139,697
				P	8,100	8,631	9,149	9,649	10,130	10,589	11,023	11,428	11,804	12,146	12,452	12,719
				A	26.1	27.3	28.5	29.8	31.0	32.1	33.2	34.3	35.2	36.1	36.9	37.6
		110	C	46,772	53,221	60,140	67,604	75,686	84,462	94,006	104,391	115,694	127,987	141,345	155,843	
			P	7,815	8,291	8,750	9,190	9,608	10,000	10,365	10,700	11,001	11,267	11,494	11,680	
			A	25.4	26.5	27.6	28.6	29.7	30.6	31.6	32.4	33.2	33.9	34.5	34.9	
		100	C	51,384	58,326	65,851	74,035	82,952	92,677	103,283	114,845	127,437	141,135	156,011	172,142	
			P	7,489	7,910	8,312	8,691	9,046	9,374	9,671	9,935	10,163	10,354	10,503	10,608	
			A	24.7	25.6	26.5	27.4	28.3	29.1	29.9	30.5	31.1	31.6	32.0	32.3	
INBDX1200M6C	3DF3R15ME-TFC	12	130	C	46,854	53,285	60,118	67,429	75,300	83,808	93,032	103,052	113,946	125,793	138,673	152,664
				P	10,510	11,174	11,844	12,517	13,189	13,857	14,519	15,170	15,809	16,432	17,036	17,617
				A	34.4	35.9	37.5	39.2	40.8	42.5	44.1	45.7	47.3	48.9	50.4	51.9
			120	C	52,574	59,628	67,223	75,439	84,355	94,048	104,600	116,087	128,590	142,187	156,957	172,979
				P	10,157	10,776	11,394	12,008	12,614	13,211	13,793	14,359	14,906	15,430	15,928	16,397
				A	33.6	35.0	36.5	37.9	39.4	40.9	42.3	43.7	45.1	46.4	47.6	48.8
		110	C	58,254	65,956	74,339	83,485	93,470	104,375	116,279	129,259	143,396	158,767	175,453	193,531	
			P	9,775	10,346	10,909	11,461	11,999	12,520	13,021	13,499	13,951	14,373	14,762	15,117	
			A	32.7	34.0	35.3	36.6	37.9	39.2	40.4	41.6	42.7	43.8	44.7	45.6	
		100	C	63,966	72,340	81,537	91,637	102,718	114,859	128,139	142,637	158,433	175,604	194,230	214,390	
			P	9,363	9,883	10,388	10,875	11,342	11,786	12,202	12,588	12,942	13,260	13,538	13,774	
			A	31.7	32.9	34.1	35.2	36.3	37.4	38.4	39.4	40.2	41.0	41.7	42.2	
INBDX1500M6C	3DS3R17ME-TFC	15	130	C	51,887	59,009	66,575	74,673	83,388	92,810	103,026	114,122	126,186	139,306	153,569	169,063
				P	11,639	12,375	13,117	13,862	14,606	15,346	16,078	16,800	17,507	18,197	18,866	19,510
				A	38.0	39.8	41.6	43.4	45.2	47.0	48.8	50.6	52.4	54.2	55.8	57.4
			120	C	58,221	66,033	74,444	83,543	93,416	104,151	115,836	128,557	142,403	157,461	173,817	191,560
				P	11,248	11,934	12,618	13,298	13,969	14,630	15,275	15,902	16,507	17,087	17,639	18,159
				A	37.2	38.8	40.4	42.0	43.7	45.3	46.9	48.4	49.9	51.4	52.8	54.1
		110	C	64,512	73,040	82,325	92,453	103,511	115,587	128,769	143,144	158,799	175,822	194,300	214,320	
			P	10,825	11,457	12,081	12,692	13,288	13,865	14,420	14,949	15,449	15,917	16,348	16,741	
			A	36.2	37.6	39.1	40.6	42.0	43.4	44.8	46.1	47.3	48.5	49.5	50.5	
		100	C	70,837	80,110	90,296	101,480	113,751	127,197	141,904	157,959	175,451	194,467	215,094	237,420	
			P	10,369	10,944	11,504	12,044	12,561	13,051	13,513	13,941	14,332	14,684	14,992	15,254	
			A	35.1	36.4	37.7	39.0	40.2	41.4	42.5	43.6	44.5	45.4	46.2	46.8	
INBDX2000M6C	4DBNR20ME-TSK	20	130	C	63,231	70,529	79,432	89,794	101,468	114,308	128,168	142,901	158,361	174,403	190,879	207,643
				P	14,664	15,545	16,445	17,358	18,276	19,193	20,102	20,996	21,867	22,710	23,516	24,279
				A	49.6	51.0	52.7	54.5	56.4	58.4	60.5	62.6	64.7	66.7	68.6	70.4
			120	C	71,984	80,309	90,358	101,984	115,042	129,384	144,866	161,340	178,660	196,680	215,253	234,234
				P	14,197	15,027	15,866	16,706	17,542	18,366	19,171	19,951	20,698	21,405	22,065	22,672
				A	48.4	49.9	51.5	53.2	55.0	56.8	58.6	60.4	62.1	63.7	65.1	66.3
		110	C	80,472	89,954	101,279	114,300	128,872	144,848	162,081	180,426	199,736	219,865	240,666	261,994	
			P	13,695	14,464	15,231	15,991	16,734	17,456	18,148	18,804	19,416	19,979	20,484	20,925	
			A	47.3	48.7	50.3	51.9	53.4	55.0	56.5	57.8	59.1	60.2	61.0	61.7	
		100	C	88,989	99,758	112,489	127,036	143,252	160,992	180,108	200,454	221,884	244,252	267,412	291,217	
			P	13,155	13,855	14,542	15,210	15,852	16,461	17,031	17,553	18,022	18,430	18,771	19,037	
			A	46.2	47.6	49.0	50.4	51.7	52.9	54.0	55.0	55.7	56.2	56.5	56.4	

INBDX

R404A

208-230V/3F/60Hz



Modelo	Compresor	H.P	TSC	TSE °F C=Capacidad Btu's/h P=Potencia watts A=Corriente Amps.												
				-10	-5	0	5	10	15	20	25	30	35	40	45	
INBDX2500M6C	4DJNR22ME-TSK	25	130	C	67,990	75,838	85,411	96,552	109,105	122,912	137,815	153,657	170,281	187,530	205,246	223,272
				P	15,600	16,537	17,495	18,466	19,443	20,418	21,385	22,336	23,263	24,159	25,017	25,829
				A	55.7	57.3	59.2	61.2	63.4	65.6	68.0	70.3	72.7	74.9	77.1	79.1
			120	C	77,403	86,354	97,159	109,660	123,701	139,123	155,770	173,484	192,107	211,484	231,455	251,864
				P	15,103	15,986	16,878	17,773	18,662	19,539	20,395	21,224	22,019	22,771	23,474	24,119
				A	54.4	56.1	57.9	59.8	61.8	63.8	65.9	67.9	69.8	71.5	73.1	74.5
		110	C	86,529	96,725	108,902	122,903	138,572	155,750	174,281	194,006	214,770	236,414	258,781	281,713	
			P	14,569	15,387	16,204	17,011	17,803	18,570	19,306	20,004	20,656	21,254	21,791	22,261	
			A	53.1	54.8	56.5	58.3	60.0	61.8	63.4	65.0	66.4	67.6	68.6	69.3	
		100	C	95,687	107,267	120,956	136,598	154,035	173,109	193,664	215,542	238,585	262,637	287,540	313,136	
			P	13,995	14,739	15,470	16,181	16,864	17,512	18,118	18,674	19,172	19,607	19,969	20,252	
			A	51.9	53.5	55.1	56.6	58.1	59.5	60.7	61.8	62.6	63.2	63.5	63.4	
INBDX3000M6C	4DJNR28ME-TSK	30	130	C	80,262	90,903	102,776	115,936	130,436	146,329	163,668	182,506	202,898	224,895	248,553	273,923
				P	18,022	19,364	20,725	22,094	23,459	24,808	26,130	27,411	28,641	29,808	30,900	31,905
				A	63.4	66.0	68.8	71.8	75.0	78.1	81.4	84.5	87.6	90.5	93.2	95.6
			120	C	90,369	102,749	116,511	131,708	148,394	166,622	186,446	207,918	231,092	256,021	282,760	311,360
				P	17,551	18,794	20,048	21,301	22,541	23,757	24,936	26,067	27,138	28,136	29,051	29,871
				A	62.4	64.8	67.3	70.0	72.8	75.7	78.5	81.3	83.9	86.4	88.6	90.5
		110	C	100,706	114,795	130,415	147,620	166,462	186,995	209,273	233,349	259,276	287,107	316,897	348,697	
			P	17,020	18,157	19,297	20,427	21,535	22,610	23,640	24,613	25,518	26,341	27,072	27,699	
			A	61.2	63.3	65.6	68.0	70.5	73.0	75.5	77.8	80.0	82.0	83.8	85.2	
		100	C	111,464	127,231	144,680	163,861	184,830	207,639	232,341	258,990	287,640	318,343	351,153	386,123	
			P	16,420	17,445	18,462	19,462	20,431	21,358	22,232	23,040	23,771	24,412	24,952	25,380	
			A	59.9	61.7	63.7	65.8	68.0	70.1	72.2	74.2	75.9	77.5	78.7	79.6	
INBDX3500M6C	6DJNR35ME-TSK	35	130	C	98,839	113,865	129,868	147,036	165,559	185,622	207,414	231,124	256,937	285,043	315,629	348,883
				P	22,403	24,162	25,914	27,643	29,338	30,984	32,568	34,077	35,497	36,816	38,019	39,093
				A	75.4	79.4	83.4	87.5	91.5	95.4	99.3	103.0	106.6	110.0	113.0	115.9
			120	C	113,791	130,309	148,106	167,370	188,288	211,048	235,839	262,847	292,261	324,269	359,057	396,815
				P	22,032	23,620	25,191	26,732	28,230	29,671	31,042	32,330	33,521	34,601	35,558	36,378
				A	74.7	78.2	81.8	85.4	88.9	92.3	95.6	98.8	101.7	104.4	106.9	109.0
		110	C	128,794	146,693	166,172	187,419	210,621	235,967	263,644	293,839	326,742	362,539	401,418	443,567	
			P	21,495	22,907	24,294	25,642	26,939	28,170	29,324	30,385	31,342	32,180	32,886	33,446	
			A	73.5	76.6	79.7	82.8	85.8	88.7	91.5	94.0	96.4	98.4	100.2	101.6	
		100	C	143,976	163,144	184,193	207,311	232,686	260,505	290,956	324,228	360,507	399,982	442,839	489,269	
			P	20,788	22,018	23,216	24,366	25,457	26,475	27,405	28,236	28,953	29,544	29,994	30,291	
			A	72.1	74.7	77.4	79.9	82.4	84.8	87.0	88.9	90.7	92.1	93.2	94.0	
INBDX4000M6C	6DJNR40ME-TSN	40	130	C	122,609	138,699	156,505	176,078	197,467	220,722	245,891	273,025	302,174	333,386	366,711	402,198
				P	27,619	29,781	31,896	33,966	35,992	37,975	39,915	41,814	43,673	45,492	47,274	49,018
				A	90.7	95.6	100.5	105.4	110.3	115.1	120.0	124.9	129.6	134.4	139.1	143.7
			120	C	139,159	157,380	177,531	199,660	223,819	250,056	278,421	308,963	341,732	376,777	414,148	453,895
				P	27,094	29,040	30,929	32,763	34,544	36,271	37,946	39,570	41,144	42,669	44,147	45,577
				A	89.5	93.8	98.1	102.4	106.7	110.9	115.1	119.2	123.2	127.1	131.0	134.8
		110	C	155,107	175,365	197,766	222,359	249,193	278,319	309,785	343,641	379,937	418,721	460,045	503,957	
			P	26,365	28,104	29,778	31,387	32,932	34,414	35,834	37,194	38,494	39,735	40,918	42,045	
			A	87.9	91.7	95.4	99.2	102.8	106.4	109.9	113.2	116.5	119.7	122.8	125.7	
		100	C	171,604	193,806	218,363	245,325	274,742	306,662	341,135	378,212	417,940	460,371	505,553	553,536	
			P	25,432	26,977	28,445	29,839	31,159	32,406	33,582	34,687	35,723	36,690	37,589	38,423	
			A	85.8	89.1	92.4	95.5	98.6	101.6	104.4	107.2	109.7	112.2	114.5	116.7	

Modelo	Compresor	H.P	TSC		TSE °F C=Capacidad Btu's/h P=Potencia watts A=Corriente Amps.														
					-10	-5	0	5	10	15	20	25	30	35	40				45
INBDX0500M6D	2DC3R53KE-TFD	5	130	C	13,574	15,661	18,004	20,615	23,506	26,688	30,174	33,975	38,102	42,568	47,384	52,562			
				P	3,241	3,461	3,692	3,931	4,174	4,416	4,653	4,881	5,096	5,295	5,472	5,624			
				A	6.1	6.3	6.5	6.8	7.0	7.3	7.6	7.8	8.1	8.3	8.5	8.7			
			120	C	15,666	18,026	20,687	23,661	26,959	30,595	34,578	38,921	43,636	48,735	54,229	60,130			
				P	3,195	3,400	3,614	3,833	4,052	4,267	4,474	4,670	4,849	5,008	5,143	5,250			
				A	6.0	6.2	6.4	6.6	6.9	7.1	7.4	7.6	7.8	8.0	8.2	8.3			
		110	C	17,785	20,430	23,422	26,771	30,490	34,591	39,085	43,984	49,299	55,044	61,228	67,865				
			P	3,125	3,315	3,510	3,707	3,900	4,087	4,263	4,424	4,566	4,684	4,775	4,835				
			A	5.9	6.1	6.3	6.5	6.7	6.9	7.1	7.3	7.5	7.6	7.7	7.8				
		100	C	19,923	22,866	26,201	29,939	34,091	38,670	43,687	49,155	55,084	61,487	68,375	75,760				
			P	3,031	3,203	3,378	3,551	3,717	3,874	4,017	4,142	4,244	4,321	4,366	4,377				
			A	5.8	6.0	6.2	6.4	6.5	6.7	6.9	7.0	7.1	7.2	7.3	7.3				
INBDX0650M6D	2DD3R63KE-TFD	6.5	130	C	17,446	19,693	22,318	25,323	28,707	32,470	36,611	41,130	46,027	51,302	56,955	62,985			
				P	3,955	4,176	4,420	4,681	4,952	5,229	5,504	5,773	6,030	6,268	6,482	6,666			
				A	6.8	7.0	7.3	7.6	7.9	8.2	8.6	8.9	9.2	9.5	9.8	10.0			
			120	C	19,700	22,356	25,432	28,928	32,845	37,181	41,937	47,113	52,707	58,721	65,153	72,003			
				P	3,856	4,069	4,299	4,542	4,791	5,040	5,284	5,516	5,732	5,924	6,087	6,216			
				A	6.7	6.9	7.2	7.4	7.7	8.0	8.3	8.5	8.8	9.0	9.2	9.4			
		110	C	22,021	25,064	28,569	32,536	36,963	41,852	47,201	53,011	59,282	66,012	73,202	80,852				
			P	3,728	3,929	4,144	4,365	4,589	4,808	5,017	5,210	5,381	5,524	5,633	5,704				
			A	6.6	6.8	7.0	7.2	7.5	7.7	7.9	8.2	8.4	8.5	8.7	8.8				
		100	C	24,447	27,857	31,769	36,184	41,101	46,520	52,441	58,864	65,788	73,213	81,140	89,567				
			P	3,580	3,767	3,962	4,160	4,355	4,541	4,712	4,862	4,986	5,077	5,130	5,139				
			A	6.4	6.6	6.8	7.0	7.2	7.4	7.6	7.8	7.9	8.0	8.1	8.1				
INBDX0750M6D	2DL3R78KE-TFD	7.5	130	C	21,706	24,811	28,242	32,022	36,172	40,716	45,675	51,072	56,929	63,268	70,111	77,481			
				P	4,903	5,215	5,541	5,876	6,215	6,554	6,888	7,214	7,526	7,819	8,091	8,336			
				A	8.6	9.0	9.3	9.7	10.1	10.5	10.9	11.2	11.6	12.0	12.3	12.7			
			120	C	24,697	28,158	32,013	36,282	40,988	46,153	51,800	57,950	64,626	71,851	79,645	88,033			
				P	4,791	5,081	5,381	5,686	5,991	6,292	6,584	6,863	7,125	7,365	7,578	7,761			
				A	8.5	8.8	9.2	9.5	9.8	10.2	10.5	10.8	11.2	11.5	11.7	12.0			
		110	C	27,686	31,506	35,785	40,545	45,807	51,595	57,931	64,836	72,333	80,444	89,192	98,598				
			P	4,646	4,913	5,186	5,459	5,729	5,991	6,240	6,472	6,682	6,867	7,021	7,139				
			A	8.4	8.7	9.0	9.3	9.5	9.8	10.1	10.4	10.6	10.9	11.1	11.2				
		100	C	30,697	34,877	39,582	44,833	50,654	57,066	64,091	71,752	80,071	89,071	98,773	109,199				
			P	4,468	4,711	4,955	5,196	5,430	5,651	5,855	6,039	6,197	6,325	6,418	6,472				
			A	8.2	8.5	8.7	9.0	9.2	9.5	9.7	9.9	10.1	10.2	10.4	10.4				
INBDX0800M6D	3DA3R10ME-TFD	8	130	C	31,294	35,851	40,690	45,857	51,394	57,345	63,754	70,665	78,122	86,168	94,847	104,203			
				P	6,901	7,380	7,850	8,309	8,753	9,181	9,590	9,976	10,339	10,674	10,979	11,253			
				A	11.6	12.2	12.7	13.2	13.8	14.3	14.8	15.2	15.7	16.1	16.5	16.8			
			120	C	35,476	40,288	45,499	51,153	57,294	63,965	71,210	79,073	87,598	96,828	106,807	117,579			
				P	6,685	7,125	7,554	7,968	8,364	8,741	9,095	9,424	9,726	9,998	10,237	10,441			
				A	11.4	11.9	12.4	12.9	13.3	13.8	14.2	14.6	14.9	15.3	15.6	15.8			
		110	C	38,993	44,183	49,888	56,152	63,019	70,532	78,736	87,673	97,388	107,925	119,326	131,637				
			P	6,438	6,837	7,222	7,588	7,934	8,257	8,555	8,824	9,063	9,269	9,439	9,571				
			A	11.1	11.6	12.0	12.4	12.8	13.2	13.5	13.9	14.1	14.4	14.6	14.8				
		100	C	42,383	48,074	54,396	61,392	69,108	77,585	86,869	97,003	108,031	119,996	132,943	146,914				
			P	6,167	6,522	6,860	7,176	7,469	7,736	7,975	8,182	8,356	8,493	8,592	8,649				
			A	10.9	11.3	11.6	12.0	12.3	12.6	12.9	13.1	13.3	13.5	13.6	13.7				

INBDX

R404A

208-230V/3F/60HZ

Modelo	Compresor	H.P	TSC	TSE °F C=Capacidad Btu's/h P=Potencia watts A=Corriente Amps.														
				-10	-5	0	5	10	15	20	25	30	35	40	45			
INBDX1000M6D	3DB3R12ME-TFD	10	130	C	37,075	42,617	48,400	54,500	60,991	67,947	75,443	83,553	92,351	101,913	112,311	123,622		
				P	8,336	8,924	9,500	10,063	10,608	11,133	11,636	12,113	12,563	12,982	13,368	13,718		
				A	13.3	14.0	14.7	15.4	16.1	16.7	17.4	18.0	18.6	19.1	19.6	20.1		
			120	C	42,030	48,012	54,350	61,119	68,393	76,246	84,753	93,988	104,026	114,940	126,806	139,697		
				P	8,100	8,631	9,149	9,649	10,130	10,589	11,023	11,428	11,804	12,146	12,452	12,719		
				A	13.0	13.6	14.3	14.9	15.5	16.1	16.6	17.1	17.6	18.1	18.5	18.8		
		110	C	46,772	53,221	60,140	67,604	75,686	84,462	94,006	104,391	115,694	127,987	141,345	155,843			
			P	7,815	8,291	8,750	9,190	9,608	10,000	10,365	10,700	11,001	11,267	11,494	11,680			
			A	12.7	13.2	13.8	14.3	14.8	15.3	15.8	16.2	16.6	16.9	17.2	17.5			
		100	C	51,384	58,326	65,851	74,035	82,952	92,677	103,283	114,845	127,437	141,135	156,011	172,142			
			P	7,489	7,910	8,312	8,691	9,046	9,374	9,671	9,935	10,163	10,354	10,503	10,608			
			A	12.3	12.8	13.3	13.7	14.1	14.6	14.9	15.3	15.6	15.8	16.0	16.1			
INBDX1200M6D	3DF3R15ME-TFD	12	130	C	46,854	53,285	60,118	67,429	75,300	83,808	93,032	103,052	113,946	125,793	138,673	152,664		
				P	10,510	11,174	11,844	12,517	13,189	13,857	14,519	15,170	15,809	16,432	17,036	17,617		
				A	17.2	18.0	18.8	19.6	20.4	21.2	22.1	22.9	23.7	24.5	25.2	25.9		
			120	C	52,574	59,628	67,223	75,439	84,355	94,048	104,600	116,087	128,590	142,187	156,957	172,979		
				P	10,157	10,776	11,394	12,008	12,614	13,211	13,793	14,359	14,906	15,430	15,928	16,397		
				A	16.8	17.5	18.2	19.0	19.7	20.4	21.2	21.9	22.5	23.2	23.8	24.4		
		110	C	58,254	65,956	74,339	83,485	93,470	104,375	116,279	129,259	143,396	158,767	175,453	193,531			
			P	9,775	10,346	10,909	11,461	11,999	12,520	13,021	13,499	13,951	14,373	14,762	15,117			
			A	16.3	17.0	17.7	18.3	19.0	19.6	20.2	20.8	21.4	21.9	22.4	22.8			
		100	C	63,966	72,340	81,537	91,637	102,718	114,859	128,139	142,637	158,433	175,604	194,230	214,390			
			P	9,363	9,883	10,388	10,875	11,342	11,786	12,202	12,588	12,942	13,260	13,538	13,774			
			A	15.9	16.5	17.0	17.6	18.2	18.7	19.2	19.7	20.1	20.5	20.8	21.1			
		INBDX1500M6D	3DS3R17ME-TFD	15	130	C	51,887	59,009	66,575	74,673	83,388	92,810	103,026	114,122	126,186	139,306	153,569	169,063
						P	11,639	12,375	13,117	13,862	14,606	15,346	16,078	16,800	17,507	18,197	18,866	19,510
						A	19.0	19.9	20.8	21.7	22.6	23.5	24.4	25.3	26.2	27.1	27.9	28.7
					120	C	58,221	66,033	74,444	83,543	93,416	104,151	115,836	128,557	142,403	157,461	173,817	191,560
						P	11,248	11,934	12,618	13,298	13,969	14,630	15,275	15,902	16,507	17,087	17,639	18,159
						A	18.6	19.4	20.2	21.0	21.8	22.6	23.4	24.2	25.0	25.7	26.4	27.0
110	C			64,512	73,040	82,325	92,453	103,511	115,587	128,769	143,144	158,799	175,822	194,300	214,320			
	P			10,825	11,457	12,081	12,692	13,288	13,865	14,420	14,949	15,449	15,917	16,348	16,741			
	A			18.1	18.8	19.6	20.3	21.0	21.7	22.4	23.0	23.6	24.2	24.8	25.2			
100	C			70,837	80,110	90,296	101,480	113,751	127,197	141,904	157,959	175,451	194,467	215,094	237,420			
	P			10,369	10,944	11,504	12,044	12,561	13,051	13,513	13,941	14,332	14,684	14,992	15,254			
	A			17.6	18.2	18.9	19.5	20.1	20.7	21.3	21.8	22.3	22.7	23.1	23.4			
INBDX2000M6D	4DBNR20ME-TSK	20	130	C	63,231	70,529	79,432	89,794	101,468	114,308	128,168	142,901	158,361	174,403	190,879	207,643		
				P	14,664	15,545	16,445	17,358	18,276	19,193	20,102	20,996	21,867	22,710	23,516	24,279		
				A	24.8	25.5	26.3	27.2	28.2	29.2	30.2	31.3	32.3	33.3	34.3	35.2		
			120	C	71,984	80,309	90,358	101,984	115,042	129,384	144,866	161,340	178,660	196,680	215,253	234,234		
				P	14,197	15,027	15,866	16,706	17,542	18,366	19,171	19,951	20,698	21,405	22,065	22,672		
				A	24.2	24.9	25.8	26.6	27.5	28.4	29.3	30.2	31.0	31.8	32.5	33.2		
		110	C	80,472	89,954	101,279	114,300	128,872	144,848	162,081	180,426	199,736	219,865	240,666	261,994			
			P	13,695	14,464	15,231	15,991	16,734	17,456	18,148	18,804	19,416	19,979	20,484	20,925			
			A	23.6	24.4	25.1	25.9	26.7	27.5	28.2	28.9	29.5	30.1	30.5	30.8			
		100	C	88,989	99,758	112,489	127,036	143,252	160,992	180,108	200,454	221,884	244,252	267,412	291,217			
			P	13,155	13,855	14,542	15,210	15,852	16,461	17,031	17,553	18,022	18,430	18,771	19,037			
			A	23.1	23.8	24.5	25.2	25.8	26.5	27.0	27.5	27.9	28.1	28.2	28.2			

Modelo	Compresor	H.P	TSC		TSE °F C=Capacidad Btu's/h P=Potencia watts A=Corriente Amps.															
					-10	-5	0	5	10	15	20	25	30	35	40				45	
INBDX2500M6D	4DHNR22ME-TSK	25	130	C	67,990	75,838	85,411	96,552	109,105	122,912	137,815	153,657	170,281	187,530	205,246	223,272				
				P	15,600	16,537	17,495	18,466	19,443	20,418	21,385	22,336	23,263	24,159	25,017	25,829				
				A	27.9	28.7	29.6	30.6	31.7	32.8	34.0	35.2	36.3	37.5	38.5	39.6				
			120	C	77,403	86,354	97,159	109,660	123,701	139,123	155,770	173,484	192,107	211,484	231,455	251,864				
				P	15,103	15,986	16,878	17,773	18,662	19,539	20,395	21,224	22,019	22,771	23,474	24,119				
				A	27.2	28.0	28.9	29.9	30.9	31.9	32.9	33.9	34.9	35.8	36.6	37.3				
			110	C	86,529	96,725	108,902	122,903	138,572	155,750	174,281	194,006	214,770	236,414	258,781	281,713				
				P	14,569	15,387	16,204	17,011	17,803	18,570	19,306	20,004	20,656	21,254	21,791	22,261				
				A	26.6	27.4	28.2	29.1	30.0	30.9	31.7	32.5	33.2	33.8	34.3	34.6				
			100	C	95,687	107,267	120,956	136,598	154,035	173,109	193,664	215,542	238,585	262,637	287,540	313,136				
				P	13,995	14,739	15,470	16,181	16,864	17,512	18,118	18,674	19,172	19,607	19,969	20,252				
				A	26.0	26.7	27.5	28.3	29.0	29.7	30.4	30.9	31.3	31.6	31.7	31.7				
INBDX3000M6D	4DJNR28ME-TSK	30	130	C	80,262	90,903	102,776	115,936	130,436	146,329	163,668	182,506	202,898	224,895	248,553	273,923				
				P	18,022	19,364	20,725	22,094	23,459	24,808	26,130	27,411	28,641	29,808	30,900	31,905				
				A	31.7	33.0	34.4	35.9	37.5	39.1	40.7	42.3	43.8	45.2	46.6	47.8				
			120	C	90,369	102,749	116,511	131,708	148,394	166,622	186,446	207,918	231,092	256,021	282,760	311,360				
				P	17,551	18,794	20,048	21,301	22,541	23,757	24,936	26,067	27,138	28,136	29,051	29,871				
				A	31.2	32.4	33.7	35.0	36.4	37.8	39.3	40.6	42.0	43.2	44.3	45.3				
			110	C	100,706	114,795	130,415	147,620	166,462	186,995	209,273	233,349	259,276	287,107	316,897	348,697				
				P	17,020	18,157	19,297	20,427	21,535	22,610	23,640	24,613	25,518	26,341	27,072	27,699				
				A	30.6	31.7	32.8	34.0	35.2	36.5	37.7	38.9	40.0	41.0	41.9	42.6				
			100	C	111,464	127,231	144,680	163,861	184,830	207,639	232,341	258,990	287,640	318,343	351,153	386,123				
				P	16,420	17,445	18,462	19,462	20,431	21,358	22,232	23,040	23,771	24,412	24,952	25,380				
				A	29.9	30.9	31.8	32.9	34.0	35.1	36.1	37.1	38.0	38.7	39.4	39.8				
INBDX3500M6D	6DHR35ME-TSK	35	130	C	98,839	113,865	129,868	147,036	165,559	185,622	207,414	231,124	256,937	285,043	315,629	348,883				
				P	22,403	24,162	25,914	27,643	29,338	30,984	32,568	34,077	35,497	36,816	38,019	39,093				
				A	37.7	39.7	41.7	43.7	45.7	47.7	49.7	51.5	53.3	55.0	56.5	57.9				
			120	C	113,791	130,309	148,106	167,370	188,288	211,048	235,839	262,847	292,261	324,269	359,057	396,815				
				P	22,032	23,620	25,191	26,732	28,230	29,671	31,042	32,330	33,521	34,601	35,558	36,378				
				A	37.3	39.1	40.9	42.7	44.4	46.1	47.8	49.4	50.9	52.2	53.4	54.5				
			110	C	128,794	146,693	166,172	187,419	210,621	235,967	263,644	293,839	326,742	362,539	401,418	443,567				
				P	21,495	22,907	24,294	25,642	26,939	28,170	29,324	30,385	31,342	32,180	32,886	33,446				
				A	36.8	38.3	39.9	41.4	42.9	44.4	45.7	47.0	48.2	49.2	50.1	50.8				
			100	C	143,976	163,144	184,193	207,311	232,686	260,505	290,956	324,228	360,507	399,982	442,839	489,269				
				P	20,788	22,018	23,216	24,366	25,457	26,475	27,405	28,236	28,953	29,544	29,994	30,291				
				A	36.0	37.4	38.7	40.0	41.2	42.4	43.5	44.5	45.3	46.1	46.6	47.0				
INBDX4000M6D	6DJNR40ME-TSN	40	130	C	122,609	138,699	156,505	176,078	197,467	220,722	245,891	273,025	302,174	333,386	366,711	402,198				
				P	27,619	29,781	31,896	33,966	35,992	37,975	39,915	41,814	43,673	45,492	47,274	49,018				
				A	45.3	47.8	50.2	52.7	55.1	57.6	60.0	62.4	64.8	67.2	69.5	71.9				
			120	C	139,159	157,380	177,531	199,660	223,819	250,056	278,421	308,963	341,732	376,777	414,148	453,895				
				P	27,094	29,040	30,929	32,763	34,544	36,271	37,946	39,570	41,144	42,669	44,147	45,577				
				A	44.7	46.9	49.1	51.2	53.3	55.5	57.5	59.6	61.6	63.6	65.5	67.4				
			110	C	155,107	175,365	197,766	222,359	249,193	278,319	309,785	343,641	379,937	418,721	460,045	503,957				
				P	26,365	28,104	29,778	31,387	32,932	34,414	35,834	37,194	38,494	39,735	40,918	42,045				
				A	43.9	45.8	47.7	49.6	51.4	53.2	54.9	56.6	58.3	59.9	61.4	62.9				
			100	C	171,604	193,806	218,363	245,325	274,742	306,662	341,135	378,212	417,940	460,371	505,553	553,536				
				P	25,432	26,977	28,445	29,839	31,159	32,406	33,582	34,687	35,723	36,690	37,589	38,423				
				A	42.9	44.6	46.2	47.8	49.3	50.8	52.2	53.6	54.9	56.1	57.3	58.3				

Modelo	Compresor	H.P	TSC	TSE °F C=Capacidad Btu's/h P=Potencia watts A=Corriente Amps.									
				-40	-35	-30	-25	-20	-15	-10	-5	0	
INBDX0300L6C	2DF3F16KE-TFC	3	130	C	4,962	7,156	9,384	11,674	14,055	16,556	19,205	22,031	25,063
				P	2,084	2,556	2,992	3,395	3,770	4,121	4,452	4,766	5,068
				A	9.4	10.2	11.0	11.8	12.6	13.4	14.1	14.9	15.6
			120	C	7,187	9,333	11,576	13,945	16,469	19,178	22,098	25,259	28,690
				P	2,346	2,756	3,134	3,484	3,810	4,116	4,406	4,683	4,953
				A	9.9	10.6	11.3	12.0	12.6	13.3	14.0	14.7	15.3
		110	C	9,109	11,249	13,551	16,043	18,755	21,714	24,950	28,491	32,365	
			P	2,509	2,865	3,192	3,495	3,778	4,045	4,301	4,548	4,791	
			A	10.1	10.8	11.4	12.0	12.6	13.2	13.8	14.4	15.0	
		100	C	10,833	13,012	15,417	18,076	21,019	24,273	27,868	31,832	36,194	
			P	2,590	2,896	3,179	3,442	3,688	3,923	4,151	4,374	4,598	
			A	10.3	10.8	11.4	11.9	12.4	12.9	13.5	14.0	14.5	
INBDX0400L6C	2DL3F20KE-TFC	4	130	C	7,407	9,465	11,650	13,991	16,512	19,241	22,205	25,428	28,939
				P	2,653	3,055	3,449	3,837	4,217	4,591	4,957	5,316	5,669
				A	12.5	13.4	14.4	15.3	16.2	17.2	18.1	19.1	20.1
			120	C	9,225	11,431	13,805	16,372	19,159	22,193	25,500	29,106	33,039
				P	2,778	3,145	3,506	3,859	4,206	4,546	4,879	5,205	5,525
				A	12.8	13.6	14.5	15.3	16.2	17.0	17.9	18.8	19.7
		110	C	11,008	13,365	15,929	18,725	21,780	25,122	28,775	32,767	37,123	
			P	2,853	3,186	3,513	3,833	4,146	4,453	4,754	5,048	5,336	
			A	13.0	13.7	14.5	15.2	16.0	16.8	17.6	18.3	19.1	
		100	C	12,761	15,272	18,029	21,057	24,383	28,034	32,036	36,415	41,198	
			P	2,883	3,183	3,477	3,764	4,045	4,320	4,589	4,851	5,108	
			A	13.1	13.7	14.4	15.1	15.7	16.4	17.1	17.8	18.5	
INBDX0500L6C	2DB3F25KE-TFC	5	130	C	10,077	12,551	15,170	17,963	20,962	24,195	27,694	31,487	35,605
				P	3,418	3,904	4,367	4,813	5,243	5,662	6,073	6,480	6,885
				A	14.2	14.9	15.8	16.7	17.7	18.7	19.6	20.6	21.5
			120	C	11,897	14,609	17,510	20,631	24,000	27,649	31,607	35,904	40,570
				P	3,450	3,906	4,339	4,755	5,157	5,547	5,930	6,309	6,686
				A	14.3	15.0	15.8	16.7	17.6	18.5	19.4	20.3	21.0
		110	C	13,754	16,683	19,844	23,270	26,988	31,030	35,426	40,205	45,397	
			P	3,467	3,888	4,288	4,671	5,039	5,397	5,747	6,094	6,441	
			A	14.2	14.9	15.7	16.5	17.3	18.2	19.0	19.7	20.4	
		100	C	15,722	18,845	22,245	25,953	29,999	34,413	39,224	44,462	50,159	
			P	3,473	3,855	4,217	4,562	4,894	5,215	5,529	5,840	6,151	
			A	14.1	14.8	15.5	16.3	17.0	17.8	18.5	19.1	19.7	
INBDX0600L6C	3DA3F28KE-TFC	6	130	C	10,113	13,258	16,537	19,977	23,607	27,454	31,546	35,910	40,573
				P	3,621	4,236	4,829	5,400	5,951	6,483	6,999	7,499	7,986
				A	14.5	15.7	16.9	18.1	19.3	20.5	21.7	22.9	24.1
			120	C	13,507	16,599	19,901	23,441	27,247	31,345	35,764	40,530	45,673
				P	3,952	4,476	4,982	5,470	5,942	6,399	6,843	7,275	7,698
				A	15.1	16.1	17.1	18.2	19.2	20.3	21.3	22.4	23.4
		110	C	16,223	19,327	22,717	26,421	30,466	34,879	39,690	44,924	50,610	
			P	4,102	4,548	4,979	5,396	5,801	6,195	6,580	6,957	7,327	
			A	15.4	16.2	17.1	18.0	18.9	19.8	20.7	21.6	22.6	
		100	C	18,476	21,656	25,198	29,130	33,479	38,272	43,538	49,304	55,598	
			P	4,119	4,499	4,868	5,227	5,577	5,920	6,258	6,591	6,922	
			A	15.4	16.1	16.9	17.7	18.4	19.2	20.0	20.8	21.6	

Modelo	Compresor	H.P	TSC	TSE °F C=Capacidad Btu's/h P=Potencia watts A=Corriente Amps.									
				-40	-35	-30	-25	-20	-15	-10	-5	0	
INBDX0750L6C	3DB3F33KE-TFC	7.5	130	C	13,427	17,249	21,098	25,038	29,135	33,456	38,066	43,029	48,413
				P	4,606	5,317	5,994	6,642	7,267	7,874	8,467	9,054	9,637
				A	17.0	18.5	20.0	21.4	22.9	24.3	25.8	27.3	28.8
			120	C	16,516	20,308	24,224	28,331	32,693	37,377	42,447	47,970	54,010
				P	4,783	5,407	6,001	6,569	7,116	7,648	8,170	8,688	9,206
				A	17.3	18.6	19.9	21.2	22.5	23.8	25.0	26.3	27.6
		110	C	19,332	23,146	27,182	31,507	36,185	41,283	46,866	52,999	59,748	
			P	4,857	5,404	5,923	6,419	6,898	7,364	7,824	8,282	8,743	
			A	17.5	18.6	19.8	20.9	22.0	23.1	24.2	25.3	26.5	
		100	C	21,883	25,770	29,978	34,572	39,618	45,181	51,328	58,123	65,633	
			P	4,840	5,318	5,772	6,205	6,624	7,034	7,440	7,847	8,261	
			A	17.5	18.5	19.5	20.4	21.4	22.3	23.3	24.3	25.3	
INBDX0900L6C	3DF3F40KE-TFC	9	130	C	17,412	21,552	25,920	30,565	35,537	40,885	46,660	52,912	59,690
				P	5,771	6,533	7,293	8,048	8,797	9,535	10,261	10,971	11,664
				A	20.7	22.3	24.0	25.6	27.3	29.1	30.8	32.6	34.4
			120	C	20,693	24,978	29,577	34,540	39,917	45,758	52,112	59,030	66,562
				P	5,854	6,540	7,226	7,909	8,587	9,256	9,914	10,559	11,188
				A	20.9	22.4	23.9	25.4	26.9	28.5	30.1	31.7	33.3
		110	C	23,725	28,182	33,041	38,351	44,162	50,524	57,486	65,100	73,413	
			P	5,856	6,471	7,088	7,703	8,314	8,918	9,513	10,096	10,665	
			A	20.9	22.2	23.5	24.9	26.3	27.7	29.1	30.5	32.0	
		100	C	26,598	31,258	36,406	42,091	48,365	55,277	62,876	71,213	80,337	
			P	5,795	6,343	6,894	7,446	7,994	8,538	9,074	9,600	10,114	
			A	20.7	21.9	23.1	24.3	25.5	26.8	28.0	29.3	30.6	
INBDX1000L6C	3DS3F46KE-TFC	10	130	C	19,242	24,036	29,036	34,286	39,832	45,720	51,995	58,702	65,888
				P	6,348	7,244	8,131	9,004	9,859	10,694	11,504	12,285	13,035
				A	21.9	23.9	25.9	28.0	30.0	32.0	34.0	36.0	38.0
			120	C	23,948	28,804	33,959	39,459	45,350	51,677	58,486	65,822	73,730
				P	6,528	7,328	8,121	8,905	9,674	10,425	11,155	11,859	12,535
				A	22.3	24.1	25.9	27.7	29.5	31.3	33.1	34.9	36.7
		110	C	27,761	32,741	38,117	43,932	50,232	57,063	64,471	72,499	81,195	
			P	6,586	7,298	8,006	8,708	9,398	10,074	10,731	11,367	11,976	
			A	22.4	23.9	25.6	27.2	28.8	30.4	32.0	33.7	35.3	
		100	C	30,841	36,012	41,673	47,868	54,642	62,042	70,112	78,899	88,447	
			P	6,537	7,169	7,800	8,427	9,047	9,655	10,248	10,822	11,373	
			A	22.2	23.6	25.0	26.5	27.9	29.4	30.9	32.3	33.8	
INBDX1200L6C	4DBNF54KE-TSK	12	130	C	14,831	22,625	29,901	36,871	43,748	50,743	58,070	65,939	74,563
				P	5,743	7,308	8,721	10,001	11,166	12,235	13,228	14,163	15,059
				A	24.3	27.7	30.8	33.7	36.4	39.0	41.4	43.8	46.2
			120	C	22,392	29,722	36,731	43,630	50,633	57,951	65,796	74,381	83,917
				P	6,714	8,005	9,165	10,213	11,167	12,048	12,874	13,664	14,437
				A	26.5	29.2	31.8	34.2	36.4	38.6	40.7	42.7	44.8
		110	C	28,436	35,455	42,348	49,329	56,610	64,402	72,919	82,371	92,971	
			P	7,256	8,309	9,253	10,107	10,889	11,618	12,315	12,997	13,683	
			A	27.6	29.8	31.9	33.9	35.7	37.5	39.3	41.1	42.9	
		100	C	33,466	40,325	47,255	54,470	62,181	70,600	79,939	90,411	102,227	
			P	7,464	8,318	9,083	9,779	10,426	11,042	11,646	12,257	12,894	
			A	27.9	29.7	31.4	33.0	34.6	36.1	37.7	39.2	40.9	

INBDX

R404A

208-230V/3F/60HZ

Modelo	Compresor	H.P	TSC	TSE °F C=Capacidad Btu's/h P=Potencia watts A=Corriente Amps.									
				-40	-35	-30	-25	-20	-15	-10	-5	0	
INBDX1500L6C	4DHNF63KE-TSK	15	130	C	26,473	33,151	39,841	46,700	53,883	61,548	69,851	78,948	88,995
				P	8,623	9,990	11,272	12,481	13,632	14,737	15,809	16,861	17,906
				A	32.9	35.6	38.3	41.0	43.6	46.3	48.9	51.6	54.3
			120	C	30,458	37,598	44,831	52,313	60,200	68,649	77,817	87,860	98,935
				P	8,965	10,153	11,262	12,306	13,297	14,247	15,172	16,082	16,992
				A	33.7	36.1	38.4	40.7	43.0	45.2	47.5	49.8	52.1
		110	C	35,290	42,911	50,705	58,829	67,439	76,692	86,744	97,751	109,872	
			P	9,134	10,170	11,132	12,035	12,892	13,714	14,516	15,311	16,111	
			A	34.0	36.0	38.1	40.0	42.0	43.9	45.9	47.8	49.8	
		100	C	40,827	48,947	57,322	66,107	75,459	85,534	96,489	108,481	121,665	
			P	9,151	10,060	10,901	11,689	12,437	13,157	13,863	14,567	15,283	
			A	33.8	35.7	37.4	39.1	40.8	42.5	44.2	45.8	47.5	
INBDX2200L6C	4DJNF76KE-TSK	22	130	C	26,265	35,794	45,173	54,536	64,017	73,746	83,858	94,485	105,760
				P	9,189	11,044	12,755	14,340	15,816	17,203	18,517	19,776	20,998
				A	35.0	39.2	43.1	46.8	50.2	53.5	56.7	59.8	62.8
			120	C	35,104	44,364	53,663	63,134	72,910	83,124	93,907	105,394	117,717
				P	9,962	11,548	13,008	14,360	15,623	16,813	17,950	19,049	20,131
				A	37.0	40.5	43.7	46.8	49.8	52.6	55.4	58.1	60.8
		110	C	42,803	52,088	61,600	71,473	81,838	92,828	104,577	117,218	130,882	
			P	10,388	11,739	12,984	14,138	15,221	16,251	17,244	18,220	19,195	
			A	38.1	41.0	43.7	46.3	48.8	51.3	53.7	56.1	58.6	
		100	C	49,553	59,156	69,174	79,741	90,989	103,050	116,057	130,144	145,443	
			P	10,526	11,678	12,742	13,734	14,672	15,576	16,461	17,347	18,251	
			A	38.5	40.9	43.1	45.3	47.5	49.6	51.8	54.0	56.4	
INBDX2700L6C	6DHNF93KE-TSK	27	130	C	33,690	43,994	55,038	66,789	79,210	92,268	105,929	120,158	134,921
				P	11,212	13,464	15,616	17,674	19,640	21,520	23,317	25,036	26,681
				A	47.2	51.4	55.7	60.0	64.3	68.7	73.0	77.3	81.5
			120	C	43,425	53,861	65,233	77,509	90,652	104,629	119,405	134,946	151,217
				P	12,431	14,337	16,162	17,912	19,591	21,202	22,751	24,240	25,675
				A	49.3	52.9	56.6	60.3	64.1	67.8	71.6	75.3	79.0
		110	C	52,173	62,891	74,742	87,692	101,707	116,752	132,794	149,796	167,725	
			P	13,029	14,636	16,183	17,674	19,114	20,505	21,852	23,161	24,433	
			A	50.3	53.4	56.6	59.8	63.0	66.3	69.6	72.9	76.1	
		100	C	60,357	71,506	83,985	97,760	112,796	129,059	146,515	165,128	184,866	
			P	13,153	14,511	15,828	17,109	18,357	19,576	20,772	21,947	23,107	
			A	50.4	53.1	55.8	58.6	61.5	64.3	67.2	70.2	73.1	
INBDX3000L6C	6DJNF11ME-TSK	30	130	C	41,472	52,816	64,505	76,668	89,432	102,926	117,278	132,615	149,068
				P	14,729	17,079	19,369	21,605	23,794	25,944	28,059	30,148	32,216
				A	55.3	60.4	65.7	70.9	76.2	81.6	87.0	92.4	97.8
			120	C	50,934	62,556	74,792	87,771	101,621	116,471	132,449	149,683	168,301
				P	15,436	17,516	19,547	21,537	23,492	25,419	27,325	29,216	31,098
				A	57.0	61.5	66.1	70.8	75.5	80.3	85.2	90.0	94.9
		110	C	60,303	72,287	85,156	99,039	114,062	130,355	148,046	167,262	188,132	
			P	15,760	17,589	19,382	21,146	22,888	24,613	26,330	28,043	29,761	
			A	57.7	61.7	65.7	69.8	74.0	78.3	82.6	87.0	91.4	
		100	C	69,286	81,721	95,310	110,182	126,465	144,288	163,778	185,063	208,273	
			P	15,771	17,371	18,947	20,506	22,054	23,599	25,146	26,703	28,276	
			A	57.7	61.1	64.7	68.3	72.0	75.8	79.7	83.6	87.6	

Modelo	Compresor	H.P	TSC	TSE °F C=Capacidad Btu's/h P=Potencia watts A=Corriente Amps.									
				-40	-35	-30	-25	-20	-15	-10	-5	0	
				INBDX0300L6D	2DF3F16KE-TFD	3	130	C	4,962	7,156	9,384	11,674	14,055
P	2,084	2,556	2,992					3,395	3,770	4,121	4,452	4,766	5,068
A	4.7	5.1	5.5					5.9	6.3	6.7	7.1	7.4	7.8
120	C	7,187	9,333				11,576	13,945	16,469	19,178	22,098	25,259	28,690
	P	2,346	2,756				3,134	3,484	3,810	4,116	4,406	4,683	4,953
	A	4.9	5.3				5.6	6.0	6.3	6.7	7.0	7.3	7.7
110	C	9,109	11,249				13,551	16,043	18,755	21,714	24,950	28,491	32,365
	P	2,509	2,865				3,192	3,495	3,778	4,045	4,301	4,548	4,791
	A	5.1	5.4				5.7	6.0	6.3	6.6	6.9	7.2	7.5
100	C	10,833	13,012			15,417	18,076	21,019	24,273	27,868	31,832	36,194	
	P	2,590	2,896			3,179	3,442	3,688	3,923	4,151	4,374	4,598	
	A	5.1	5.4			5.7	5.9	6.2	6.5	6.7	7.0	7.3	
INBDX0400L6D	2DL3F20KE-TFD	4	130	C	7,407	9,465	11,650	13,991	16,512	19,241	22,205	25,428	28,939
				P	2,653	3,055	3,449	3,837	4,217	4,591	4,957	5,316	5,669
				A	6.3	6.7	7.2	7.6	8.1	8.6	9.1	9.5	10.0
			120	C	9,225	11,431	13,805	16,372	19,159	22,193	25,500	29,106	33,039
				P	2,778	3,145	3,506	3,859	4,206	4,546	4,879	5,205	5,525
				A	6.4	6.8	7.2	7.7	8.1	8.5	8.9	9.4	9.8
			110	C	11,008	13,365	15,929	18,725	21,780	25,122	28,775	32,767	37,123
				P	2,853	3,186	3,513	3,833	4,146	4,453	4,754	5,048	5,336
				A	6.5	6.9	7.2	7.6	8.0	8.4	8.8	9.2	9.6
		100	C	12,761	15,272	18,029	21,057	24,383	28,034	32,036	36,415	41,198	
			P	2,883	3,183	3,477	3,764	4,045	4,320	4,589	4,851	5,108	
			A	6.5	6.9	7.2	7.5	7.9	8.2	8.6	8.9	9.3	
INBDX0500L6D	2DB3F25KE-TFD	5	130	C	10,077	12,551	15,170	17,963	20,962	24,195	27,694	31,487	35,605
				P	3,418	3,904	4,367	4,813	5,243	5,662	6,073	6,480	6,885
				A	7.1	7.5	7.9	8.4	8.8	9.3	9.8	10.3	10.8
			120	C	11,897	14,609	17,510	20,631	24,000	27,649	31,607	35,904	40,570
				P	3,450	3,906	4,339	4,755	5,157	5,547	5,930	6,309	6,686
				A	7.1	7.5	7.9	8.3	8.8	9.2	9.7	10.1	10.5
			110	C	13,754	16,683	19,844	23,270	26,988	31,030	35,426	40,205	45,397
				P	3,467	3,888	4,288	4,671	5,039	5,397	5,747	6,094	6,441
				A	7.1	7.5	7.9	8.3	8.7	9.1	9.5	9.9	10.2
		100	C	15,722	18,845	22,245	25,953	29,999	34,413	39,224	44,462	50,159	
			P	3,473	3,855	4,217	4,562	4,894	5,215	5,529	5,840	6,151	
			A	7.1	7.4	7.8	8.1	8.5	8.9	9.2	9.6	9.8	
INBDX0600L6D	3DA3F28KE-TFD	6	130	C	10,113	13,258	16,537	19,977	23,607	27,454	31,546	35,910	40,573
				P	3,621	4,236	4,829	5,400	5,951	6,483	6,999	7,499	7,986
				A	7.3	7.8	8.4	9.0	9.6	10.2	10.9	11.5	12.1
			120	C	13,507	16,599	19,901	23,441	27,247	31,345	35,764	40,530	45,673
				P	3,952	4,476	4,982	5,470	5,942	6,399	6,843	7,275	7,698
				A	7.5	8.1	8.6	9.1	9.6	10.1	10.7	11.2	11.7
			110	C	16,223	19,327	22,717	26,421	30,466	34,879	39,690	44,924	50,610
				P	4,102	4,548	4,979	5,396	5,801	6,195	6,580	6,957	7,327
				A	7.7	8.1	8.6	9.0	9.5	9.9	10.4	10.8	11.3
		100	C	18,476	21,656	25,198	29,130	33,479	38,272	43,538	49,304	55,598	
			P	4,119	4,499	4,868	5,227	5,577	5,920	6,258	6,591	6,922	
			A	7.7	8.1	8.5	8.8	9.2	9.6	10.0	10.4	10.8	

INBDX

R404A

460V-3F-60HZ

Modelo	Compresor	H.P	TSC	TSE °F C=Capacidad Btu's/h P=Potencia watts A=Corriente Amps.									
				-40	-35	-30	-25	-20	-15	-10	-5	0	
INBDX0750L6D	3DB3F33KE-TFD	7.5	130	C	13,427	17,249	21,098	25,038	29,135	33,456	38,066	43,029	48,413
				P	4,606	5,317	5,994	6,642	7,267	7,874	8,467	9,054	9,637
				A	8.5	9.2	10.0	10.7	11.4	12.2	12.9	13.6	14.4
			120	C	16,516	20,308	24,224	28,331	32,693	37,377	42,447	47,970	54,010
				P	4,783	5,407	6,001	6,569	7,116	7,648	8,170	8,688	9,206
				A	8.7	9.3	10.0	10.6	11.2	11.9	12.5	13.2	13.8
		110	C	19,332	23,146	27,182	31,507	36,185	41,283	46,866	52,999	59,748	
			P	4,857	5,404	5,923	6,419	6,898	7,364	7,824	8,282	8,743	
			A	8.7	9.3	9.9	10.4	11.0	11.5	12.1	12.7	13.2	
		100	C	21,883	25,770	29,978	34,572	39,618	45,181	51,328	58,123	65,633	
			P	4,840	5,318	5,772	6,205	6,624	7,034	7,440	7,847	8,261	
			A	8.7	9.2	9.7	10.2	10.7	11.2	11.7	12.1	12.7	
INBDX0900L6D	3DF3F40KE-TFD	9	130	C	17,412	21,552	25,920	30,565	35,537	40,885	46,660	52,912	59,690
				P	5,771	6,533	7,293	8,048	8,797	9,535	10,261	10,971	11,664
				A	10.3	11.1	12.0	12.8	13.7	14.5	15.4	16.3	17.2
			120	C	20,693	24,978	29,577	34,540	39,917	45,758	52,112	59,030	66,562
				P	5,854	6,540	7,226	7,909	8,587	9,256	9,914	10,559	11,188
				A	10.5	11.2	11.9	12.7	13.5	14.2	15.0	15.8	16.6
		110	C	23,725	28,182	33,041	38,351	44,162	50,524	57,486	65,100	73,413	
			P	5,856	6,471	7,088	7,703	8,314	8,918	9,513	10,096	10,665	
			A	10.5	11.1	11.8	12.5	13.1	13.8	14.5	15.3	16.0	
		100	C	26,598	31,258	36,406	42,091	48,365	55,277	62,876	71,213	80,337	
			P	5,795	6,343	6,894	7,446	7,994	8,538	9,074	9,600	10,114	
			A	10.4	11.0	11.5	12.1	12.8	13.4	14.0	14.7	15.3	
INBDX1000L6D	3DS3F46KE-TFD	10	130	C	19,242	24,036	29,036	34,286	39,832	45,720	51,995	58,702	65,888
				P	6,348	7,244	8,131	9,004	9,859	10,694	11,504	12,285	13,035
				A	10.9	11.9	13.0	14.0	15.0	16.0	17.0	18.0	19.0
			120	C	23,948	28,804	33,959	39,459	45,350	51,677	58,486	65,822	73,730
				P	6,528	7,328	8,121	8,905	9,674	10,425	11,155	11,859	12,535
				A	11.1	12.0	12.9	13.8	14.7	15.7	16.6	17.5	18.4
		110	C	27,761	32,741	38,117	43,932	50,232	57,063	64,471	72,499	81,195	
			P	6,586	7,298	8,006	8,708	9,398	10,074	10,731	11,367	11,976	
			A	11.2	12.0	12.8	13.6	14.4	15.2	16.0	16.8	17.7	
		100	C	30,841	36,012	41,673	47,868	54,642	62,042	70,112	78,899	88,447	
			P	6,537	7,169	7,800	8,427	9,047	9,655	10,248	10,822	11,373	
			A	11.1	11.8	12.5	13.2	14.0	14.7	15.4	16.2	16.9	
INBDX1200L6D	4DBNF54KE-TSK	12	130	C	14,831	22,625	29,901	36,871	43,748	50,743	58,070	65,939	74,563
				P	5,743	7,308	8,721	10,001	11,166	12,235	13,228	14,163	15,059
				A	12.2	13.8	15.4	16.8	18.2	19.5	20.7	21.9	23.1
			120	C	22,392	29,722	36,731	43,630	50,633	57,951	65,796	74,381	83,917
				P	6,714	8,005	9,165	10,213	11,167	12,048	12,874	13,664	14,437
				A	13.2	14.6	15.9	17.1	18.2	19.3	20.3	21.4	22.4
		110	C	28,436	35,455	42,348	49,329	56,610	64,402	72,919	82,371	92,971	
			P	7,256	8,309	9,253	10,107	10,889	11,618	12,315	12,997	13,683	
			A	13.8	14.9	16.0	16.9	17.9	18.8	19.7	20.5	21.4	
		100	C	33,466	40,325	47,255	54,470	62,181	70,600	79,939	90,411	102,227	
			P	7,464	8,318	9,083	9,779	10,426	11,042	11,646	12,257	12,894	
			A	14.0	14.9	15.7	16.5	17.3	18.1	18.8	19.6	20.4	

Modelo	Compresor	H.P	TSC	TSE °F C=Capacidad Btu's/h P=Potencia watts A=Corriente Amps.									
				-40	-35	-30	-25	-20	-15	-10	-5	0	
INBDX1500L6D	4DHN63KE-TSK	15	130	C	26,473	33,151	39,841	46,700	53,883	61,548	69,851	78,948	88,995
				P	8,623	9,990	11,272	12,481	13,632	14,737	15,809	16,861	17,906
				A	16.4	17.8	19.2	20.5	21.8	23.1	24.5	25.8	27.2
			120	C	30,458	37,598	44,831	52,313	60,200	68,649	77,817	87,860	98,935
				P	8,965	10,153	11,262	12,306	13,297	14,247	15,172	16,082	16,992
				A	16.9	18.0	19.2	20.4	21.5	22.6	23.7	24.9	26.0
		110	C	35,290	42,911	50,705	58,829	67,439	76,692	86,744	97,751	109,872	
			P	9,134	10,170	11,132	12,035	12,892	13,714	14,516	15,311	16,111	
			A	17.0	18.0	19.0	20.0	21.0	22.0	22.9	23.9	24.9	
		100	C	40,827	48,947	57,322	66,107	75,459	85,534	96,489	108,481	121,665	
			P	9,151	10,060	10,901	11,689	12,437	13,157	13,863	14,567	15,283	
			A	16.9	17.8	18.7	19.6	20.4	21.3	22.1	22.9	23.8	
INBDX2200L6D	4DJN76KE-TSK	22	130	C	26,265	35,794	45,173	54,536	64,017	73,746	83,858	94,485	105,760
				P	9,189	11,044	12,755	14,340	15,816	17,203	18,517	19,776	20,998
				A	17.5	19.6	21.6	23.4	25.1	26.8	28.4	29.9	31.4
			120	C	35,104	44,364	53,663	63,134	72,910	83,124	93,907	105,394	117,717
				P	9,962	11,548	13,008	14,360	15,623	16,813	17,950	19,049	20,131
				A	18.5	20.2	21.9	23.4	24.9	26.3	27.7	29.0	30.4
		110	C	42,803	52,088	61,600	71,473	81,838	92,828	104,577	117,218	130,882	
			P	10,388	11,739	12,984	14,138	15,221	16,251	17,244	18,220	19,195	
			A	19.1	20.5	21.9	23.2	24.4	25.6	26.8	28.1	29.3	
		100	C	49,553	59,156	69,174	79,741	90,989	103,050	116,057	130,144	145,443	
			P	10,526	11,678	12,742	13,734	14,672	15,576	16,461	17,347	18,251	
			A	19.3	20.4	21.6	22.7	23.7	24.8	25.9	27.0	28.2	
INBDX2700L6D	6DHN93KE-TSK	27	130	C	33,690	43,994	55,038	66,789	79,210	92,268	105,929	120,158	134,921
				P	11,212	13,464	15,616	17,674	19,640	21,520	23,317	25,036	26,681
				A	23.6	25.7	27.9	30.0	32.2	34.3	36.5	38.6	40.7
			120	C	43,425	53,861	65,233	77,509	90,652	104,629	119,405	134,946	151,217
				P	12,431	14,337	16,162	17,912	19,591	21,202	22,751	24,240	25,675
				A	24.7	26.5	28.3	30.2	32.0	33.9	35.8	37.7	39.5
		110	C	52,173	62,891	74,742	87,692	101,707	116,752	132,794	149,796	167,725	
			P	13,029	14,636	16,183	17,674	19,114	20,505	21,852	23,161	24,433	
			A	25.1	26.7	28.3	29.9	31.5	33.2	34.8	36.4	38.1	
		100	C	60,357	71,506	83,985	97,760	112,796	129,059	146,515	165,128	184,866	
			P	13,153	14,511	15,828	17,109	18,357	19,576	20,772	21,947	23,107	
			A	25.2	26.5	27.9	29.3	30.7	32.2	33.6	35.1	36.5	
INBDX3000L6D	6DJN11ME-TSK	30	130	C	41,472	52,816	64,505	76,668	89,432	102,926	117,278	132,615	149,068
				P	14,729	17,079	19,369	21,605	23,794	25,944	28,059	30,148	32,216
				A	27.6	30.2	32.8	35.5	38.1	40.8	43.5	46.2	48.9
			120	C	50,934	62,556	74,792	87,771	101,621	116,471	132,449	149,683	168,301
				P	15,436	17,516	19,547	21,537	23,492	25,419	27,325	29,216	31,098
				A	28.5	30.8	33.1	35.4	37.8	40.2	42.6	45.0	47.5
		110	C	60,303	72,287	85,156	99,039	114,062	130,355	148,046	167,262	188,132	
			P	15,760	17,589	19,382	21,146	22,888	24,613	26,330	28,043	29,761	
			A	28.9	30.8	32.9	34.9	37.0	39.1	41.3	43.5	45.7	
		100	C	69,286	81,721	95,310	110,182	126,465	144,288	163,778	185,063	208,273	
			P	15,771	17,371	18,947	20,506	22,054	23,599	25,146	26,703	28,276	
			A	28.9	30.6	32.3	34.1	36.0	37.9	39.8	41.8	43.8	

INBDX

R404A

460V-3F-60HZ

Modelo	Compresor	H.P	TSC	TSE % C=Capacidad Btu's/h P=Potencia watts A=Corriente Amps.												
				-10	-5	0	5	10	15	20	25	30	35	40	45	
INBBX1000M6C	4VES10Y-2NU	10	130	C	28,595	33,191	38,277	43,900	50,110	56,955	64,482	72,742	81,781	91,649	102,393	114,063
				P	6,533	7,138	7,747	8,356	8,961	9,557	10,139	10,705	11,250	11,769	12,258	12,714
				A	21.6	22.9	24.2	25.6	27.0	28.4	29.8	31.2	32.6	33.9	35.1	36.3
			120	C	33,601	38,851	44,647	51,038	58,073	65,799	74,265	83,519	93,611	104,588	116,498	129,391
				P	6,452	7,013	7,573	8,129	8,676	9,209	9,726	10,221	10,690	11,129	11,535	11,902
				A	21.4	22.6	23.8	25.1	26.3	27.6	28.8	30.0	31.2	32.3	33.3	34.3
		110	C	38,656	44,556	51,060	58,215	66,071	74,675	84,076	94,323	105,463	117,546	130,619	144,732	
			P	6,338	6,851	7,359	7,858	8,344	8,812	9,259	9,680	10,071	10,427	10,745	11,021	
			A	21.1	22.2	23.3	24.5	25.6	26.7	27.7	28.7	29.7	30.6	31.4	32.1	
		100	C	43,772	50,320	57,527	65,444	74,117	83,596	93,928	105,164	117,350	130,535	144,768	160,097	
			P	6,191	6,653	7,106	7,545	7,967	8,367	8,740	9,084	9,393	9,663	9,891	10,071	
			A	20.8	21.8	22.8	23.7	24.7	25.6	26.5	27.3	28.1	28.7	29.3	29.7	
INBBX1200M6C	4TES12Y-2NU	12	130	C	35,821	41,319	47,400	54,121	61,540	69,715	78,703	88,564	99,353	111,131	123,953	137,879
				P	8,244	8,968	9,698	10,430	11,157	11,874	12,577	13,258	13,913	14,537	15,124	15,668
				A	25.6	27.3	28.9	30.7	32.4	34.2	35.9	37.6	39.3	40.9	42.5	43.9
			120	C	41,743	48,018	54,943	62,575	70,974	80,196	90,300	101,344	113,384	126,480	140,689	156,069
				P	8,066	8,738	9,412	10,081	10,740	11,383	12,006	12,602	13,167	13,694	14,179	14,615
				A	25.2	26.7	28.3	29.8	31.4	32.9	34.5	35.9	37.4	38.7	40.0	41.2
		110	C	47,692	54,740	62,504	71,045	80,419	90,685	101,900	114,122	127,409	141,820	157,411	174,240	
			P	7,861	8,477	9,089	9,691	10,278	10,843	11,382	11,888	12,358	12,784	13,163	13,487	
			A	24.8	26.1	27.5	28.9	30.3	31.6	32.9	34.2	35.3	36.4	37.4	38.3	
		100	C	53,690	61,505	70,106	79,551	89,896	101,201	113,523	126,920	141,450	157,171	174,140	192,415	
			P	7,627	8,184	8,730	9,260	9,770	10,252	10,703	11,116	11,486	11,807	12,075	12,283	
			A	24.3	25.5	26.7	27.9	29.1	30.2	31.3	32.3	33.2	34.0	34.7	35.2	
INBBX1500M6C	4PES15Y-2NU	15	130	C	38,605	44,965	52,017	59,830	68,473	78,014	88,522	100,065	112,711	126,531	141,591	157,961
				P	8,857	9,727	10,605	11,484	12,358	13,220	14,065	14,887	15,677	16,431	17,142	17,804
				A	30.0	31.7	33.6	35.5	37.5	39.5	41.5	43.4	45.4	47.3	49.2	50.9
			120	C	45,610	52,892	60,946	69,839	79,641	90,419	102,243	115,180	129,300	144,672	161,362	179,441
				P	8,792	9,599	10,407	11,209	12,000	12,773	13,522	14,241	14,922	15,560	16,149	16,681
				A	29.8	31.4	33.1	34.9	36.6	38.4	40.1	41.9	43.5	45.1	46.6	48.0
		110	C	52,710	60,910	69,959	79,926	90,880	102,889	116,023	130,349	145,936	162,853	181,168	200,950	
			P	8,673	9,411	10,145	10,866	11,570	12,249	12,897	13,508	14,075	14,593	15,054	15,453	
			A	29.6	31.0	32.6	34.1	35.6	37.2	38.7	40.1	41.5	42.8	43.9	45.0	
		100	C	59,918	69,028	79,066	90,101	102,201	115,436	129,873	145,581	162,629	181,085	201,019	222,498	
			P	8,500	9,167	9,821	10,457	11,068	11,648	12,190	12,689	13,138	13,530	13,859	14,120	
			A	29.2	30.5	31.9	33.2	34.5	35.8	37.1	38.2	39.3	40.2	41.1	41.7	
INBBX2000M6C	4NES20Y-2NU	20	130	C	49,084	56,550	64,814	73,955	84,052	95,184	107,433	120,876	135,593	151,665	169,169	188,187
				P	11,211	12,175	13,150	14,128	15,101	16,063	17,005	17,920	18,801	19,640	20,429	21,161
				A	35.4	37.5	39.6	41.8	44.1	46.3	48.6	50.9	53.1	55.3	57.3	59.3
			120	C	57,131	65,658	75,075	85,460	96,894	109,455	123,224	138,279	154,701	172,568	191,960	212,957
				P	10,954	11,851	12,750	13,645	14,528	15,391	16,227	17,028	17,786	18,495	19,146	19,733
				A	34.9	36.8	38.7	40.7	42.7	44.7	46.7	48.6	50.5	52.3	54.0	55.6
		110	C	65,210	74,792	85,356	96,980	109,744	123,727	139,010	155,671	173,790	193,446	214,720	237,689	
			P	10,665	11,488	12,307	13,112	13,898	14,656	15,380	16,060	16,690	17,263	17,770	18,205	
			A	34.3	36.0	37.7	39.5	41.2	42.9	44.6	46.3	47.8	49.2	50.5	51.7	
		100	C	73,352	83,983	95,686	108,542	122,630	138,030	154,820	173,080	192,890	214,330	237,478	262,415	
			P	10,342	11,086	11,817	12,527	13,210	13,857	14,462	15,016	15,511	15,942	16,299	16,575	
			A	33.6	35.1	36.6	38.2	39.7	41.1	42.5	43.8	45.0	46.0	46.9	47.7	

Modelo	Compresor	H.P	TSC	TSE °F C=Capacidad Btu's/h P=Potencia watts A=Corriente Amps.												
				-10	-5	0	5	10	15	20	25	30	35	40	45	
INBBX2200M6C	4JE22Y-2NU	22	130	C	55,074	63,669	73,093	83,426	94,747	107,137	120,675	135,443	151,519	168,983	187,916	208,398
				P	12,300	13,396	14,493	15,585	16,667	17,732	18,777	19,794	20,780	21,728	22,632	23,489
				A	37.8	40.2	42.6	45.2	47.8	50.4	53.0	55.6	58.2	60.7	63.1	65.5
		120	C	64,522	74,263	84,926	96,591	109,339	123,250	138,403	154,879	172,757	192,118	213,041	235,607	
			P	12,229	13,230	14,225	15,207	16,173	17,116	18,031	18,913	19,755	20,553	21,301	21,994	
			A	37.5	39.7	42.0	44.3	46.6	48.9	51.1	53.4	55.5	57.6	59.6	61.5	
	110	C	73,923	84,784	96,661	109,635	123,785	139,192	155,935	174,094	193,750	214,982	237,870	262,495		
		P	12,045	12,947	13,836	14,706	15,552	16,369	17,151	17,892	18,588	19,233	19,821	20,346		
		A	37.1	39.1	41.1	43.1	45.1	47.0	49.0	50.8	52.6	54.3	55.8	57.2		
	100	C	83,268	95,225	108,292	122,550	138,077	154,955	173,263	193,081	214,490	237,569	262,397	289,057		
		P	11,752	12,551	13,330	14,084	14,807	15,494	16,139	16,737	17,283	17,770	18,194	18,550		
		A	36.5	38.2	39.9	41.6	43.3	44.9	46.5	48.0	49.4	50.6	51.7	52.6		
INBBX2500M6C	4HE25Y-2NU	25	130	C	67,532	77,402	88,215	100,062	113,038	127,234	142,742	159,657	178,070	198,073	219,761	243,224
				P	14,973	16,209	17,447	18,680	19,902	21,107	22,288	23,439	24,554	25,626	26,649	27,617
				A	47.3	50.0	52.8	55.7	58.5	61.4	64.3	67.2	70.0	72.7	75.4	77.9
		120	C	78,385	89,614	101,898	115,329	129,999	146,002	163,430	182,376	202,931	225,190	249,244	275,187	
			P	14,790	15,927	17,058	18,177	19,277	20,352	21,396	22,403	23,366	24,278	25,134	25,927	
			A	46.9	49.4	51.9	54.4	57.0	59.6	62.1	64.6	67.0	69.3	71.5	73.6	
	110	C	89,117	101,671	115,390	130,369	146,700	164,475	183,787	204,728	227,392	251,871	278,257	306,643		
		P	14,491	15,523	16,542	17,541	18,514	19,455	20,356	21,213	22,018	22,765	23,448	24,060		
		A	46.2	48.4	50.7	53.0	55.2	57.4	59.6	61.7	63.6	65.5	67.3	68.8		
	100	C	99,715	113,557	128,678	145,170	163,126	182,638	203,799	226,701	251,438	278,102	306,785	337,581		
		P	14,078	15,001	15,902	16,776	17,616	18,416	19,170	19,871	20,512	21,089	21,593	22,020		
		A	45.3	47.3	49.3	51.2	53.1	55.0	56.8	58.4	60.0	61.4	62.7	63.8		
INBBX3000M6C	4GE30Y-2NU	30	130	C	78,542	89,674	101,871	115,238	129,883	145,911	163,429	182,543	203,359	225,985	250,525	277,087
				P	17,391	18,792	20,196	21,595	22,982	24,350	25,693	27,002	28,271	29,494	30,662	31,769
				A	56.5	59.5	62.7	65.9	69.2	72.4	75.7	79.0	82.2	85.3	88.3	91.2
		120	C	90,955	103,692	117,626	132,862	149,508	167,668	187,451	208,961	232,306	257,591	284,924	314,409	
			P	17,148	18,445	19,736	21,014	22,272	23,504	24,701	25,857	26,964	28,017	29,007	29,928	
			A	55.9	58.7	61.6	64.5	67.4	70.4	73.3	76.1	78.9	81.5	84.1	86.4	
	110	C	103,202	117,496	133,118	150,175	168,773	189,018	211,016	234,875	260,699	288,596	318,672	351,034		
		P	16,774	17,960	19,131	20,282	21,404	22,490	23,535	24,530	25,469	26,344	27,149	27,876		
		A	55.1	57.6	60.2	62.8	65.4	68.0	70.5	72.9	75.2	77.4	79.4	81.2		
	100	C	115,249	131,051	148,314	167,142	187,644	209,925	234,091	260,249	288,505	318,966	351,737	386,925		
		P	16,274	17,340	18,384	19,399	20,378	21,313	22,197	23,024	23,787	24,477	25,090	25,616		
		A	54.0	56.3	58.5	60.8	63.0	65.2	67.3	69.3	71.1	72.8	74.3	75.6		
INBBX3300M6C	6JE33Y-2NU	33	130	C	81,141	93,980	108,085	123,575	140,568	159,184	179,542	201,761	225,961	252,260	280,779	311,635
				P	18,172	19,795	21,401	22,982	24,528	26,030	27,479	28,866	30,180	31,414	32,558	33,603
				A	62.9	66.2	69.5	72.9	76.3	79.7	83.1	86.4	89.6	92.7	95.6	98.3
		120	C	95,148	109,639	125,526	142,927	161,962	182,750	205,410	230,062	256,825	285,817	317,158	350,968	
			P	18,083	19,566	21,025	22,450	23,833	25,164	26,434	27,634	28,754	29,785	30,719	31,545	
			A	62.6	65.6	68.6	71.7	74.7	77.7	80.7	83.5	86.2	88.8	91.1	93.2	
	110	C	109,068	125,176	142,810	162,089	183,132	206,058	230,986	258,037	287,328	318,979	353,109	389,838		
		P	17,822	19,160	20,466	21,731	22,945	24,100	25,186	26,194	27,114	27,938	28,656	29,259		
		A	62.1	64.7	67.4	70.1	72.7	75.3	77.8	80.2	82.4	84.4	86.1	87.7		
	100	C	122,899	140,591	159,938	181,060	204,077	229,107	256,270	285,685	317,470	351,746	388,631	428,245		
		P	17,393	18,581	19,729	20,829	21,870	22,843	23,739	24,550	25,266	25,877	26,374	26,749		
		A	61.2	63.5	65.9	68.2	70.4	72.6	74.6	76.5	78.1	79.6	80.8	81.7		

		TSE °F C=Capacidad Btu's/h P=Potencia watts A=Corriente Amps.														
Modelo	Compresor	H.P	TSC	-10	-5	0	5	10	15	20	25	30	35	40	45	
INBBX3500M6C	6HE35Y-2NU	35	130	C	99,325	113,934	129,919	147,414	166,554	187,474	210,309	235,196	262,268	291,661	323,510	357,951
				P	22,673	24,519	26,350	28,156	29,927	31,652	33,323	34,929	36,460	37,907	39,260	40,508
				A	72.4	76.5	80.6	84.8	89.0	93.2	97.3	101.3	105.2	108.9	112.4	115.7
		120	C	115,330	131,863	149,937	169,688	191,251	214,760	240,351	268,160	298,320	330,968	366,239	404,267	
			P	22,337	24,022	25,684	27,313	28,898	30,431	31,900	33,297	34,611	35,833	36,952	37,959	
			A	71.6	75.3	79.0	82.8	86.5	90.2	93.8	97.3	100.6	103.7	106.6	109.2	
	110	C	131,063	149,489	169,622	191,598	215,552	241,620	269,936	300,635	333,853	369,724	408,385	449,970		
		P	21,799	23,321	24,811	26,260	27,658	28,994	30,260	31,445	32,539	33,532	34,416	35,178		
		A	70.3	73.7	77.0	80.3	83.6	86.8	89.9	92.8	95.5	98.0	100.2	102.2		
	100	C	146,594	166,881	189,042	213,212	239,527	268,122	299,131	332,690	368,935	407,999	450,019	495,130		
		P	21,083	22,438	23,753	25,020	26,227	27,365	28,424	29,394	30,265	31,028	31,672	32,188		
		A	68.7	71.7	74.6	77.5	80.3	83.0	85.5	87.9	90.0	91.9	93.5	94.7		
INBBX4000M6C	6GE40Y-2NU	40	130	C	115,239	131,570	149,369	168,785	189,970	213,074	238,247	265,641	295,406	327,692	362,651	400,432
				P	26,523	28,602	30,666	32,703	34,705	36,661	38,562	40,398	42,158	43,833	45,414	46,890
				A	89.4	93.7	98.1	102.5	106.9	111.3	115.6	119.8	123.9	127.8	131.5	135.0
		120	C	133,472	152,013	172,231	194,278	218,305	244,460	272,897	303,764	337,213	373,394	412,458	454,556	
			P	26,106	28,003	29,876	31,715	33,511	35,253	36,932	38,538	40,061	41,492	42,819	44,034	
			A	88.5	92.4	96.4	100.3	104.3	108.1	111.9	115.6	119.1	122.4	125.5	128.3	
	110	C	151,193	171,927	194,549	219,210	246,062	275,253	306,936	341,260	378,376	418,436	461,589	507,986		
		P	25,458	27,173	28,856	30,498	32,089	33,618	35,076	36,454	37,740	38,926	40,002	40,957		
		A	87.1	90.6	94.2	97.7	101.2	104.6	107.8	111.0	113.9	116.6	119.1	121.2		
	100	C	168,587	191,497	216,507	243,766	273,426	305,636	340,549	378,313	419,081	463,002	510,227	560,908		
		P	24,613	26,147	27,641	29,087	30,473	31,790	33,028	34,178	35,229	36,172	36,997	37,693		
		A	85.4	88.5	91.6	94.7	97.7	100.6	103.4	105.9	108.3	110.4	112.3	113.8		
INBBX5000M6C	6FE50Y-2NU	50	130	C	142,086	161,994	183,591	207,061	232,588	260,357	290,551	323,356	358,955	397,533	439,274	484,362
				P	32,017	34,669	37,303	39,907	42,466	44,967	47,397	49,741	51,986	54,118	56,125	57,991
				A	124.1	129.8	135.3	140.7	146.0	151.0	155.8	160.3	164.5	168.3	171.7	174.6
		120	C	164,208	186,820	211,391	238,106	267,149	298,703	332,954	370,085	410,282	453,727	500,606	551,102	
			P	31,737	34,166	36,567	38,925	41,227	43,460	45,609	47,661	49,603	51,421	53,100	54,628	
			A	123.5	128.8	133.9	138.8	143.6	148.2	152.5	156.5	160.2	163.5	166.3	168.7	
	110	C	185,793	211,059	238,555	268,465	300,972	336,263	374,520	415,928	460,671	508,934	560,901	616,755		
		P	31,164	33,364	35,525	37,631	39,670	41,627	43,490	45,245	46,877	48,373	49,720	50,903		
		A	122.3	127.1	131.7	136.2	140.6	144.6	148.4	151.9	155.0	157.8	160.1	161.9		
	100	C	206,863	234,733	265,103	298,157	334,080	373,056	415,269	460,904	510,144	563,174	620,178	681,341		
		P	30,313	32,279	34,192	36,041	37,810	39,486	41,056	42,506	43,822	44,991	45,998	46,831		
		A	120.5	124.8	128.9	133.0	136.8	140.3	143.6	146.5	149.1	151.3	153.0	154.2		

Modelo	Compresor	H.P	TSC	TSE °F C=Capacidad Btu's/h P=Potencia watts A=Corriente Amps.												
				-10	-5	0	5	10	15	20	25	30	35	40	45	
INBBX1000M6D	4VES10Y-2NU	10	130	C	28,595	33,191	38,277	43,900	50,110	56,955	64,482	72,742	81,781	91,649	102,393	114,063
				P	6,533	7,138	7,747	8,356	8,961	9,557	10,139	10,705	11,250	11,769	12,258	12,714
				A	10.8	11.4	12.1	12.8	13.5	14.2	14.9	15.6	16.3	16.9	17.6	18.2
			120	C	33,601	38,851	44,647	51,038	58,073	65,799	74,265	83,519	93,611	104,588	116,498	129,391
				P	6,452	7,013	7,573	8,129	8,676	9,209	9,726	10,221	10,690	11,129	11,535	11,902
				A	10.7	11.3	11.9	12.5	13.2	13.8	14.4	15.0	15.6	16.1	16.7	17.1
		110	C	38,656	44,556	51,060	58,215	66,071	74,675	84,076	94,323	105,463	117,546	130,619	144,732	
			P	6,338	6,851	7,359	7,858	8,344	8,812	9,259	9,680	10,071	10,427	10,745	11,021	
			A	10.6	11.1	11.7	12.2	12.8	13.3	13.9	14.4	14.8	15.3	15.7	16.0	
		100	C	43,772	50,320	57,527	65,444	74,117	83,596	93,928	105,164	117,350	130,535	144,768	160,097	
			P	6,191	6,653	7,106	7,545	7,967	8,367	8,740	9,084	9,393	9,663	9,891	10,071	
			A	10.4	10.9	11.4	11.9	12.4	12.8	13.3	13.7	14.0	14.4	14.6	14.9	
INBBX1200M6D	4TES12Y-2NU	12	130	C	35,821	41,319	47,400	54,121	61,540	69,715	78,703	88,564	99,353	111,131	123,953	137,879
				P	8,244	8,968	9,698	10,430	11,157	11,874	12,577	13,258	13,913	14,537	15,124	15,668
				A	12.8	13.6	14.5	15.3	16.2	17.1	17.9	18.8	19.6	20.5	21.2	22.0
			120	C	41,743	48,018	54,943	62,575	70,974	80,196	90,300	101,344	113,384	126,480	140,689	156,069
				P	8,066	8,738	9,412	10,081	10,740	11,383	12,006	12,602	13,167	13,694	14,179	14,615
				A	12.6	13.4	14.1	14.9	15.7	16.5	17.2	18.0	18.7	19.4	20.0	20.6
		110	C	47,692	54,740	62,504	71,045	80,419	90,685	101,900	114,122	127,409	141,820	157,411	174,240	
			P	7,861	8,477	9,089	9,691	10,278	10,843	11,382	11,888	12,358	12,784	13,163	13,487	
			A	12.4	13.1	13.8	14.4	15.1	15.8	16.5	17.1	17.7	18.2	18.7	19.1	
		100	C	53,690	61,505	70,106	79,551	89,896	101,201	113,523	126,920	141,450	157,171	174,140	192,415	
			P	7,627	8,184	8,730	9,260	9,770	10,252	10,703	11,116	11,486	11,807	12,075	12,283	
			A	12.1	12.7	13.3	13.9	14.5	15.1	15.6	16.1	16.6	17.0	17.3	17.6	
INBBX1500M6D	4PES15Y-2NU	15	130	C	38,605	44,965	52,017	59,830	68,473	78,014	88,522	100,065	112,711	126,531	141,591	157,961
				P	8,857	9,727	10,605	11,484	12,358	13,220	14,065	14,887	15,677	16,431	17,142	17,804
				A	15.0	15.9	16.8	17.8	18.7	19.7	20.7	21.7	22.7	23.7	24.6	25.5
			120	C	45,610	52,892	60,946	69,839	79,641	90,419	102,243	115,180	129,300	144,672	161,362	179,441
				P	8,792	9,599	10,407	11,209	12,000	12,773	13,522	14,241	14,922	15,560	16,149	16,681
				A	14.9	15.7	16.6	17.4	18.3	19.2	20.1	20.9	21.8	22.6	23.3	24.0
		110	C	52,710	60,910	69,959	79,926	90,880	102,889	116,023	130,349	145,936	162,853	181,168	200,950	
			P	8,673	9,411	10,145	10,866	11,570	12,249	12,897	13,508	14,075	14,593	15,054	15,453	
			A	14.8	15.5	16.3	17.1	17.8	18.6	19.3	20.1	20.7	21.4	22.0	22.5	
		100	C	59,918	69,028	79,066	90,101	102,201	115,436	129,873	145,581	162,629	181,085	201,019	222,498	
			P	8,500	9,167	9,821	10,457	11,068	11,648	12,190	12,689	13,138	13,530	13,859	14,120	
			A	14.6	15.3	15.9	16.6	17.3	17.9	18.5	19.1	19.6	20.1	20.5	20.9	
INBBX2000M6D	4NES20Y-2NU	20	130	C	49,084	56,550	64,814	73,955	84,052	95,184	107,433	120,876	135,593	151,665	169,169	188,187
				P	11,211	12,175	13,150	14,128	15,101	16,063	17,005	17,920	18,801	19,640	20,429	21,161
				A	17.7	18.7	19.8	20.9	22.0	23.2	24.3	25.4	26.5	27.6	28.7	29.7
			120	C	57,131	65,658	75,075	85,460	96,894	109,455	123,224	138,279	154,701	172,568	191,960	212,957
				P	10,954	11,851	12,750	13,645	14,528	15,391	16,227	17,028	17,786	18,495	19,146	19,733
				A	17.4	18.4	19.3	20.3	21.3	22.3	23.3	24.3	25.3	26.2	27.0	27.8
		110	C	65,210	74,792	85,356	96,980	109,744	123,727	139,010	155,671	173,790	193,446	214,720	237,689	
			P	10,665	11,488	12,307	13,112	13,898	14,656	15,380	16,060	16,690	17,263	17,770	18,205	
			A	17.1	18.0	18.9	19.7	20.6	21.5	22.3	23.1	23.9	24.6	25.3	25.9	
		100	C	73,352	83,983	95,686	108,542	122,630	138,030	154,820	173,080	192,890	214,330	237,478	262,415	
			P	10,342	11,086	11,817	12,527	13,210	13,857	14,462	15,016	15,511	15,942	16,299	16,575	
			A	16.8	17.6	18.3	19.1	19.8	20.6	21.2	21.9	22.5	23.0	23.5	23.8	

Modelo	Compresor	H.P	TSC	TSE % C=Capacidad Btu's/h P=Potencia watts A=Corriente Amps.												
				-10	-5	0	5	10	15	20	25	30	35	40	45	
INBBX2200M6D	4JE22Y-2NU	22	130	C	55,074	63,669	73,093	83,426	94,747	107,137	120,675	135,443	151,519	168,983	187,916	208,398
				P	12,300	13,396	14,493	15,585	16,667	17,732	18,777	19,794	20,780	21,728	22,632	23,489
				A	18.9	20.1	21.3	22.6	23.9	25.2	26.5	27.8	29.1	30.4	31.6	32.7
		120	C	64,522	74,263	84,926	96,591	109,339	123,250	138,403	154,879	172,757	192,118	213,041	235,607	
			P	12,229	13,230	14,225	15,207	16,173	17,116	18,031	18,913	19,755	20,553	21,301	21,994	
			A	18.8	19.9	21.0	22.1	23.3	24.4	25.6	26.7	27.8	28.8	29.8	30.8	
	110	C	73,923	84,784	96,661	109,635	123,785	139,192	155,935	174,094	193,750	214,982	237,870	262,495		
		P	12,045	12,947	13,836	14,706	15,552	16,369	17,151	17,892	18,588	19,233	19,821	20,346		
		A	18.6	19.5	20.5	21.5	22.5	23.5	24.5	25.4	26.3	27.1	27.9	28.6		
	100	C	83,268	95,225	108,292	122,550	138,077	154,955	173,263	193,081	214,490	237,569	262,397	289,057		
		P	11,752	12,551	13,330	14,084	14,807	15,494	16,139	16,737	17,283	17,770	18,194	18,550		
		A	18.2	19.1	20.0	20.8	21.7	22.5	23.3	24.0	24.7	25.3	25.8	26.3		
INBBX2500M6D	4HE25Y-2NU	25	130	C	67,532	77,402	88,215	100,062	113,038	127,234	142,742	159,657	178,070	198,073	219,761	243,224
				P	14,973	16,209	17,447	18,680	19,902	21,107	22,288	23,439	24,554	25,626	26,649	27,617
				A	23.7	25.0	26.4	27.8	29.3	30.7	32.1	33.6	35.0	36.4	37.7	39.0
		120	C	78,385	89,614	101,898	115,329	129,999	146,002	163,430	182,376	202,931	225,190	249,244	275,187	
			P	14,790	15,927	17,058	18,177	19,277	20,352	21,396	22,403	23,366	24,278	25,134	25,927	
			A	23.5	24.7	25.9	27.2	28.5	29.8	31.0	32.3	33.5	34.6	35.7	36.8	
	110	C	89,117	101,671	115,390	130,369	146,700	164,475	183,787	204,728	227,392	251,871	278,257	306,643		
		P	14,491	15,523	16,542	17,541	18,514	19,455	20,356	21,213	22,018	22,765	23,448	24,060		
		A	23.1	24.2	25.3	26.5	27.6	28.7	29.8	30.8	31.8	32.8	33.6	34.4		
	100	C	99,715	113,557	128,678	145,170	163,126	182,638	203,799	226,701	251,438	278,102	306,785	337,581		
		P	14,078	15,001	15,902	16,776	17,616	18,416	19,170	19,871	20,512	21,089	21,593	22,020		
		A	22.7	23.6	24.6	25.6	26.6	27.5	28.4	29.2	30.0	30.7	31.3	31.9		
INBBX3000M6D	4GE30Y-2NU	30	130	C	78,542	89,674	101,871	115,238	129,883	145,911	163,429	182,543	203,359	225,985	250,525	277,087
				P	17,391	18,792	20,196	21,595	22,982	24,350	25,693	27,002	28,271	29,494	30,662	31,769
				A	28.2	29.8	31.3	32.9	34.6	36.2	37.9	39.5	41.1	42.6	44.1	45.6
		120	C	90,955	103,692	117,626	132,862	149,508	167,668	187,451	208,961	232,306	257,591	284,924	314,409	
			P	17,148	18,445	19,736	21,014	22,272	23,504	24,701	25,857	26,964	28,017	29,007	29,928	
			A	28.0	29.4	30.8	32.3	33.7	35.2	36.6	38.1	39.4	40.8	42.0	43.2	
	110	C	103,202	117,496	133,118	150,175	168,773	189,018	211,016	234,875	260,699	288,596	318,672	351,034		
		P	16,774	17,960	19,131	20,282	21,404	22,490	23,535	24,530	25,469	26,344	27,149	27,876		
		A	27.6	28.8	30.1	31.4	32.7	34.0	35.2	36.4	37.6	38.7	39.7	40.6		
	100	C	115,249	131,051	148,314	167,142	187,644	209,925	234,091	260,249	288,505	318,966	351,737	386,925		
		P	16,274	17,340	18,384	19,399	20,378	21,313	22,197	23,024	23,787	24,477	25,090	25,616		
		A	27.0	28.1	29.3	30.4	31.5	32.6	33.7	34.6	35.6	36.4	37.2	37.8		
INBBX3300M6D	6JE33Y-2NU	33	130	C	81,141	93,980	108,085	123,575	140,568	159,184	179,542	201,761	225,961	252,260	280,779	311,635
				P	18,172	19,795	21,401	22,982	24,528	26,030	27,479	28,866	30,180	31,414	32,558	33,603
				A	31.5	33.1	34.7	36.4	38.2	39.9	41.6	43.2	44.8	46.4	47.8	49.2
		120	C	95,148	109,639	125,526	142,927	161,962	182,750	205,410	230,062	256,825	285,817	317,158	350,968	
			P	18,083	19,566	21,025	22,450	23,833	25,164	26,434	27,634	28,754	29,785	30,719	31,545	
			A	31.3	32.8	34.3	35.8	37.4	38.9	40.3	41.8	43.1	44.4	45.6	46.6	
	110	C	109,068	125,176	142,810	162,089	183,132	206,058	230,986	258,037	287,328	318,979	353,109	389,838		
		P	17,822	19,160	20,466	21,731	22,945	24,100	25,186	26,194	27,114	27,938	28,656	29,259		
		A	31.0	32.4	33.7	35.0	36.4	37.7	38.9	40.1	41.2	42.2	43.1	43.8		
	100	C	122,899	140,591	159,938	181,060	204,077	229,107	256,270	285,685	317,470	351,746	388,631	428,245		
		P	17,393	18,581	19,729	20,829	21,870	22,843	23,739	24,550	25,266	25,877	26,374	26,749		
		A	30.6	31.8	32.9	34.1	35.2	36.3	37.3	38.2	39.1	39.8	40.4	40.8		

TSE °F C=Capacidad Btu's/h P=Potencia watts A=Corriente Amps.																
Modelo	Compresor	H.P	TSC	-10	-5	0	5	10	15	20	25	30	35	40	45	
INBBX3500M6D	6HE35Y-2NU	35	130	C	99,325	113,934	129,919	147,414	166,554	187,474	210,309	235,196	262,268	291,661	323,510	357,951
				P	22,673	24,519	26,350	28,156	29,927	31,652	33,323	34,929	36,460	37,907	39,260	40,508
				A	36.2	38.2	40.3	42.4	44.5	46.6	48.7	50.7	52.6	54.5	56.2	57.8
			120	C	115,330	131,863	149,937	169,688	191,251	214,760	240,351	268,160	298,320	330,968	366,239	404,267
				P	22,337	24,022	25,684	27,313	28,898	30,431	31,900	33,297	34,611	35,833	36,952	37,959
				A	35.8	37.6	39.5	41.4	43.3	45.1	46.9	48.6	50.3	51.9	53.3	54.6
		110	C	131,063	149,489	169,622	191,598	215,552	241,620	269,936	300,635	333,853	369,724	408,385	449,970	
			P	21,799	23,321	24,811	26,260	27,658	28,994	30,260	31,445	32,539	33,532	34,416	35,178	
			A	35.2	36.8	38.5	40.2	41.8	43.4	44.9	46.4	47.8	49.0	50.1	51.1	
		100	C	146,594	166,881	189,042	213,212	239,527	268,122	299,131	332,690	368,935	407,999	450,019	495,130	
			P	21,083	22,438	23,753	25,020	26,227	27,365	28,424	29,394	30,265	31,028	31,672	32,188	
			A	34.4	35.8	37.3	38.8	40.2	41.5	42.8	43.9	45.0	46.0	46.7	47.4	
INBBX4000M6D	6GE40Y-2NU	40	130	C	115,239	131,570	149,369	168,785	189,970	213,074	238,247	265,641	295,406	327,692	362,651	400,432
				P	26,523	28,602	30,666	32,703	34,705	36,661	38,562	40,398	42,158	43,833	45,414	46,890
				A	44.7	46.9	49.0	51.3	53.5	55.6	57.8	59.9	61.9	63.9	65.8	67.5
			120	C	133,472	152,013	172,231	194,278	218,305	244,460	272,897	303,764	337,213	373,394	412,458	454,556
				P	26,106	28,003	29,876	31,715	33,511	35,253	36,932	38,538	40,061	41,492	42,819	44,034
				A	44.2	46.2	48.2	50.2	52.1	54.1	56.0	57.8	59.6	61.2	62.8	64.2
		110	C	151,193	171,927	194,549	219,210	246,062	275,253	306,936	341,260	378,376	418,436	461,589	507,986	
			P	25,458	27,173	28,856	30,498	32,089	33,618	35,076	36,454	37,740	38,926	40,002	40,957	
			A	43.6	45.3	47.1	48.8	50.6	52.3	53.9	55.5	56.9	58.3	59.5	60.6	
		100	C	168,587	191,497	216,507	243,766	273,426	305,636	340,549	378,313	419,081	463,002	510,227	560,908	
			P	24,613	26,147	27,641	29,087	30,473	31,790	33,028	34,178	35,229	36,172	36,997	37,693	
			A	42.7	44.3	45.8	47.4	48.9	50.3	51.7	53.0	54.2	55.2	56.1	56.9	
INBBX5000M6D	6FE50Y-2NU	50	130	C	142,086	161,994	183,591	207,061	232,588	260,357	290,551	323,356	358,955	397,533	439,274	484,362
				P	32,017	34,669	37,303	39,907	42,466	44,967	47,397	49,741	51,986	54,118	56,125	57,991
				A	62.1	64.9	67.6	70.4	73.0	75.5	77.9	80.1	82.2	84.1	85.8	87.3
			120	C	164,208	186,820	211,391	238,106	267,149	298,703	332,954	370,085	410,282	453,727	500,606	551,102
				P	31,737	34,166	36,567	38,925	41,227	43,460	45,609	47,661	49,603	51,421	53,100	54,628
				A	61.8	64.4	66.9	69.4	71.8	74.1	76.2	78.2	80.1	81.7	83.2	84.4
		110	C	185,793	211,059	238,555	268,465	300,972	336,263	374,520	415,928	460,671	508,934	560,901	616,755	
			P	31,164	33,364	35,525	37,631	39,670	41,627	43,490	45,245	46,877	48,373	49,720	50,903	
			A	61.2	63.5	65.9	68.1	70.3	72.3	74.2	76.0	77.5	78.9	80.0	81.0	
		100	C	206,863	234,733	265,103	298,157	334,080	373,056	415,269	460,904	510,144	563,174	620,178	681,341	
			P	30,313	32,279	34,192	36,041	37,810	39,486	41,056	42,506	43,822	44,991	45,998	46,831	
			A	60.2	62.4	64.5	66.5	68.4	70.2	71.8	73.3	74.5	75.6	76.5	77.1	

MBBX

R404A

208-230V/3F/60HZ

Modelo	Compresor	H.P	TSC	TSE °F C=Capacidad Btu's/h P=Potencia watts A=Corriente Amps.									
				-40	-35	-30	-25	-20	-15	-10	-5	0	
INBBX1000L6C	4PE512Y-2NU	12	130	C	11,090	14,606	18,458	22,708	27,420	32,660	38,490	44,974	52,177
				P	3,879	4,610	5,385	6,196	7,038	7,905	8,791	9,689	10,595
				A	16.4	17.7	19.2	20.9	22.7	24.6	26.7	28.8	31.0
			120	C	14,342	18,342	22,746	27,618	33,022	39,021	45,679	53,062	61,231
				P	4,189	4,887	5,622	6,388	7,178	7,986	8,807	9,634	10,462
				A	17.0	18.3	19.7	21.3	23.0	24.8	26.7	28.6	30.6
		110	C	17,740	22,211	27,155	32,636	38,718	45,464	52,938	61,206	70,329	
			P	4,432	5,094	5,785	6,501	7,235	7,981	8,733	9,485	10,230	
			A	17.4	18.6	20.0	21.5	23.1	24.7	26.5	28.3	30.1	
		100	C	21,261	26,190	31,661	37,738	44,485	51,966	60,244	69,383	79,448	
			P	4,613	5,234	5,878	6,540	7,214	7,893	8,572	9,244	9,904	
			A	17.7	18.9	20.2	21.5	23.0	24.5	26.1	27.7	29.3	
INBBX1400L6C	4NE514Y-2NU	14	130	C	15,412	19,623	24,213	29,259	34,833	41,010	47,863	55,467	63,897
				P	5,103	5,994	6,929	7,902	8,905	9,931	10,974	12,026	13,081
				A	19.2	20.9	22.8	24.9	27.2	29.5	32.0	34.6	37.2
			120	C	19,333	24,104	29,337	35,105	41,482	48,542	56,360	65,009	74,563
				P	5,491	6,333	7,214	8,125	9,060	10,011	10,972	11,936	12,895
				A	20.0	21.6	23.4	25.4	27.5	29.7	32.0	34.3	36.7
		110	C	23,355	28,660	34,506	40,969	48,121	56,037	64,790	74,456	85,108	
			P	5,771	6,561	7,383	8,228	9,091	9,963	10,838	11,709	12,568	
			A	20.5	22.1	23.8	25.6	27.5	29.5	31.6	33.7	35.9	
		100	C	27,440	33,250	39,683	46,811	54,710	63,453	73,115	83,769	95,490	
			P	5,949	6,683	7,441	8,217	9,002	9,791	10,576	11,350	12,106	
			A	20.9	22.3	23.9	25.5	27.3	29.1	31.0	32.8	34.7	
INBBX1500L6C	4JE15Y-2NU	15	130	C	19,644	24,824	30,418	36,502	43,151	50,439	58,442	67,234	76,890
				P	6,817	7,776	8,773	9,803	10,858	11,933	13,023	14,121	15,223
				A	27.4	28.9	30.7	32.6	34.7	37.0	39.3	41.8	44.3
			120	C	24,114	29,901	36,184	43,039	50,540	58,762	67,781	77,671	88,506
				P	7,065	7,974	8,913	9,877	10,859	11,854	12,857	13,861	14,860
				A	27.8	29.3	30.9	32.7	34.7	36.8	38.9	41.2	43.5
		110	C	28,672	35,048	42,002	49,610	57,946	67,085	77,102	88,072	100,069	
			P	7,239	8,092	8,969	9,863	10,769	11,680	12,591	13,497	14,390	
			A	28.1	29.5	31.0	32.7	34.5	36.3	38.3	40.3	42.3	
		100	C	33,298	40,246	47,854	56,198	65,351	75,389	86,387	98,419	111,560	
			P	7,338	8,133	8,944	9,764	10,589	11,413	12,228	13,031	13,815	
			A	28.3	29.5	31.0	32.5	34.1	35.8	37.5	39.2	41.0	
INBBX1800L6C	4HE18Y-2NU	18	130	C	25,477	31,431	37,854	44,833	52,453	60,802	69,966	80,033	91,088
				P	8,470	9,567	10,714	11,905	13,134	14,393	15,676	16,974	18,283
				A	30.1	32.1	34.4	36.9	39.6	42.5	45.5	48.6	51.9
			120	C	30,441	37,121	44,366	52,264	60,900	70,362	80,737	92,110	104,569
				P	8,650	9,694	10,781	11,902	13,052	14,222	15,407	16,599	17,791
				A	30.4	32.4	34.5	36.9	39.4	42.0	44.8	47.7	50.6
		110	C	35,499	42,877	50,918	59,708	69,333	79,882	91,439	104,092	117,928	
			P	8,754	9,741	10,761	11,807	12,871	13,948	15,030	16,109	17,180	
			A	30.6	32.5	34.5	36.6	38.9	41.4	43.9	46.4	49.1	
		100	C	40,623	48,672	57,481	67,136	77,723	89,330	102,043	115,948	131,134	
			P	8,784	9,708	10,656	11,621	12,595	13,572	14,545	15,508	16,452	
			A	30.7	32.4	34.2	36.2	38.3	40.5	42.7	45.0	47.3	

Modelo	Compresor	H.P	TSC	TSE °F C=Capacidad Btu's/h P=Potencia watts A=Corriente Amps.										
				-40	-35	-30	-25	-20	-15	-10	-5	0		
INBBX2300L6C	4GE23Y-2NU	23	130	C	32,631	39,377	46,647	54,539	63,153	72,589	82,946	94,325	106,824	
				P	10,407	11,660	12,980	14,359	15,789	17,262	18,769	20,304	21,858	
				A	33.7	36.3	39.2	42.4	45.8	49.4	53.1	57.1	61.1	
			120	C	38,027	45,637	53,884	62,868	72,687	83,442	95,232	108,157	122,315	
				P	10,493	11,692	12,947	14,250	15,593	16,967	18,365	19,779	21,200	
				A	33.9	36.4	39.1	42.1	45.3	48.6	52.1	55.7	59.4	
		110	C	43,535	51,969	61,154	71,189	82,173	94,206	107,388	121,819	137,597		
			P	10,503	11,642	12,825	14,045	15,293	16,562	17,843	19,128	20,410		
			A	33.9	36.3	38.9	41.6	44.5	47.6	50.8	54.0	57.3		
		100	C	49,109	58,327	68,409	79,454	91,562	104,834	119,367	135,263	152,619		
			P	10,439	11,510	12,615	13,745	14,892	16,048	17,205	18,355	19,490		
			A	33.8	36.0	38.4	40.9	43.6	46.3	49.2	52.0	54.9		
INBBX2800L6C	4FE28Y-2NU	28	130	C	36,644	45,464	54,783	64,717	75,380	86,890	99,362	112,912	127,656	
				P	11,818	13,478	15,191	16,947	18,737	20,550	22,376	24,205	26,028	
				A	45.4	48.5	51.9	55.6	59.5	63.6	67.8	72.1	76.6	
			120	C	44,231	53,833	64,092	75,124	87,045	99,970	114,015	129,298	145,932	
				P	12,178	13,736	15,339	16,976	18,638	20,314	21,995	23,670	25,330	
				A	46.1	49.0	52.2	55.6	59.2	63.0	66.9	70.8	74.8	
		110	C	51,613	61,973	73,148	85,254	98,408	112,724	128,320	145,310	163,811		
			P	12,388	13,839	15,327	16,841	18,370	19,905	21,436	22,953	24,445		
			A	46.5	49.2	52.2	55.3	58.6	62.0	65.5	69.1	72.7		
		100	C	58,803	69,896	81,964	95,121	109,484	125,167	142,289	160,963	181,307		
			P	12,454	13,796	15,164	16,549	17,942	19,332	20,708	22,062	23,382		
			A	46.6	49.1	51.8	54.6	57.6	60.7	63.8	67.0	70.1		
INBBX3400L6C	6GE34Y-2NU	34	130	C	49,880	60,330	71,471	83,444	96,392	110,456	125,780	142,506	160,775	
				P	16,170	18,139	20,186	22,298	24,464	26,671	28,908	31,164	33,424	
				A	53.8	58.1	62.7	67.7	72.9	78.3	83.8	89.5	95.2	
			120	C	58,947	70,427	82,782	96,155	110,687	126,521	143,798	162,662	183,255	
				P	16,358	18,192	20,092	22,046	24,042	26,067	28,111	30,160	32,204	
				A	54.2	58.2	62.5	67.1	71.8	76.7	81.8	86.9	92.1	
		110	C	67,535	80,032	93,590	108,350	124,454	142,044	161,264	182,255	205,159		
			P	16,343	18,044	19,800	21,598	23,425	25,271	27,123	28,969	30,797		
			A	54.2	57.9	61.8	66.0	70.3	74.7	79.3	83.9	88.5		
		100	C	75,825	89,328	104,076	120,211	137,875	157,210	178,360	201,465	226,668		
			P	16,156	17,727	19,340	20,984	22,645	24,313	25,975	27,619	29,234		
			A	53.8	57.2	60.7	64.5	68.4	72.4	76.5	80.5	84.6		
INBBX4400L6C	6FE44Y-2NU	44	130	C	54,966	68,197	82,175	97,075	113,070	130,335	149,043	169,368	191,484	
				P	18,626	21,065	23,577	26,146	28,757	31,398	34,053	36,708	39,348	
				A	74.0	78.6	83.5	88.7	94.1	99.8	105.6	111.5	117.5	
			120	C	66,346	80,750	96,138	112,686	130,567	149,955	171,023	193,946	218,898	
				P	19,152	21,442	23,792	26,188	28,614	31,057	33,502	35,934	38,340	
				A	75.1	79.3	83.9	88.7	93.8	99.0	104.3	109.7	115.1	
		110	C	77,419	92,959	109,722	127,882	147,612	169,087	192,480	217,965	245,717		
			P	19,458	21,593	23,776	25,991	28,225	30,463	32,692	34,895	37,061		
			A	75.7	79.6	83.9	88.3	92.9	97.7	102.5	107.3	112.2		
		100	C	88,204	104,845	122,946	142,682	164,225	187,751	213,433	241,445	271,961		
			P	19,557	21,530	23,538	25,567	27,602	29,629	31,634	33,602	35,520		
			A	75.8	79.5	83.3	87.4	91.6	95.8	100.2	104.5	108.7		

MBBX

R404A

208-230V/3F/60HZ

Modelo	Compresor	H.P	TSC	TSE °F C=Capacidad Btu's/h P=Potencia watts A=Corriente Amps.									
				-40	-35	-30	-25	-20	-15	-10	-5	0	
INBBX1000L6D	4PE512Y-2NU	12	130	C	11,090	14,606	18,458	22,708	27,420	32,660	38,490	44,974	52,177
				P	3,879	4,610	5,385	6,196	7,038	7,905	8,791	9,689	10,595
				A	8.2	8.9	9.6	10.4	11.3	12.3	13.3	14.4	15.5
			120	C	14,342	18,342	22,746	27,618	33,022	39,021	45,679	53,062	61,231
				P	4,189	4,887	5,622	6,388	7,178	7,986	8,807	9,634	10,462
				A	8.5	9.1	9.8	10.6	11.5	12.4	13.3	14.3	15.3
		110	C	17,740	22,211	27,155	32,636	38,718	45,464	52,938	61,206	70,329	
			P	4,432	5,094	5,785	6,501	7,235	7,981	8,733	9,485	10,230	
			A	8.7	9.3	10.0	10.7	11.5	12.4	13.2	14.1	15.0	
		100	C	21,261	26,190	31,661	37,738	44,485	51,966	60,244	69,383	79,448	
			P	4,613	5,234	5,878	6,540	7,214	7,893	8,572	9,244	9,904	
			A	8.9	9.4	10.1	10.8	11.5	12.3	13.0	13.8	14.6	
INBBX1400L6D	4NE514Y-2NU	14	130	C	15,412	19,623	24,213	29,259	34,833	41,010	47,863	55,467	63,897
				P	5,103	5,994	6,929	7,902	8,905	9,931	10,974	12,026	13,081
				A	9.6	10.5	11.4	12.5	13.6	14.8	16.0	17.3	18.6
			120	C	19,333	24,104	29,337	35,105	41,482	48,542	56,360	65,009	74,563
				P	5,491	6,333	7,214	8,125	9,060	10,011	10,972	11,936	12,895
				A	10.0	10.8	11.7	12.7	13.7	14.8	16.0	17.2	18.4
		110	C	23,355	28,660	34,506	40,969	48,121	56,037	64,790	74,456	85,108	
			P	5,771	6,561	7,383	8,228	9,091	9,963	10,838	11,709	12,568	
			A	10.3	11.0	11.9	12.8	13.8	14.8	15.8	16.9	17.9	
		100	C	27,440	33,250	39,683	46,811	54,710	63,453	73,115	83,769	95,490	
			P	5,949	6,683	7,441	8,217	9,002	9,791	10,576	11,350	12,106	
			A	10.4	11.1	11.9	12.8	13.6	14.6	15.5	16.4	17.4	
INBBX1500L6C	4JE15Y-2NU	15	130	C	19,644	24,824	30,418	36,502	43,151	50,439	58,442	67,234	76,890
				P	6,817	7,776	8,773	9,803	10,858	11,933	13,023	14,121	15,223
				A	13.7	14.5	15.3	16.3	17.4	18.5	19.7	20.9	22.2
			120	C	24,114	29,901	36,184	43,039	50,540	58,762	67,781	77,671	88,506
				P	7,065	7,974	8,913	9,877	10,859	11,854	12,857	13,861	14,860
				A	13.9	14.6	15.5	16.4	17.3	18.4	19.5	20.6	21.7
		110	C	28,672	35,048	42,002	49,610	57,946	67,085	77,102	88,072	100,069	
			P	7,239	8,092	8,969	9,863	10,769	11,680	12,591	13,497	14,390	
			A	14.1	14.7	15.5	16.3	17.2	18.2	19.1	20.1	21.2	
		100	C	33,298	40,246	47,854	56,198	65,351	75,389	86,387	98,419	111,560	
			P	7,338	8,133	8,944	9,764	10,589	11,413	12,228	13,031	13,815	
			A	14.1	14.8	15.5	16.2	17.0	17.9	18.7	19.6	20.5	
INBBX1800L6C	4HE18Y-2NU	18	130	C	25,477	31,431	37,854	44,833	52,453	60,802	69,966	80,033	91,088
				P	8,470	9,567	10,714	11,905	13,134	14,393	15,676	16,974	18,283
				A	15.0	16.0	17.2	18.4	19.8	21.2	22.7	24.3	25.9
			120	C	30,441	37,121	44,366	52,264	60,900	70,362	80,737	92,110	104,569
				P	8,650	9,694	10,781	11,902	13,052	14,222	15,407	16,599	17,791
				A	15.2	16.2	17.3	18.4	19.7	21.0	22.4	23.8	25.3
		110	C	35,499	42,877	50,918	59,708	69,333	79,882	91,439	104,092	117,928	
			P	8,754	9,741	10,761	11,807	12,871	13,948	15,030	16,109	17,180	
			A	15.3	16.2	17.2	18.3	19.5	20.7	21.9	23.2	24.5	
		100	C	40,623	48,672	57,481	67,136	77,723	89,330	102,043	115,948	131,134	
			P	8,784	9,708	10,656	11,621	12,595	13,572	14,545	15,508	16,452	
			A	15.3	16.2	17.1	18.1	19.2	20.2	21.4	22.5	23.6	

Modelo	Compresor	H.P	TSC	TSE °F C=Capacidad Btu's/h P=Potencia watts A=Corriente Amps.									
				-40	-35	-30	-25	-20	-15	-10	-5	0	
INBBX2300L6C	4GE23Y-2NU	23	130	C	32,631	39,377	46,647	54,539	63,153	72,589	82,946	94,325	106,824
				P	10,407	11,660	12,980	14,359	15,789	17,262	18,769	20,304	21,858
				A	16.8	18.2	19.6	21.2	22.9	24.7	26.6	28.5	30.5
			120	C	38,027	45,637	53,884	62,868	72,687	83,442	95,232	108,157	122,315
				P	10,493	11,692	12,947	14,250	15,593	16,967	18,365	19,779	21,200
				A	17.0	18.2	19.6	21.1	22.6	24.3	26.0	27.8	29.7
		110	C	43,535	51,969	61,154	71,189	82,173	94,206	107,388	121,819	137,597	
			P	10,503	11,642	12,825	14,045	15,293	16,562	17,843	19,128	20,410	
			A	17.0	18.1	19.4	20.8	22.3	23.8	25.4	27.0	28.6	
		100	C	49,109	58,327	68,409	79,454	91,562	104,834	119,367	135,263	152,619	
			P	10,439	11,510	12,615	13,745	14,892	16,048	17,205	18,355	19,490	
			A	16.9	18.0	19.2	20.4	21.8	23.2	24.6	26.0	27.5	
INBBX2800L6C	4FE28Y-2NU	28	130	C	36,644	45,464	54,783	64,717	75,380	86,890	99,362	112,912	127,656
				P	11,818	13,478	15,191	16,947	18,737	20,550	22,376	24,205	26,028
				A	22.7	24.3	26.0	27.8	29.7	31.8	33.9	36.1	38.3
			120	C	44,231	53,833	64,092	75,124	87,045	99,970	114,015	129,298	145,932
				P	12,178	13,736	15,339	16,976	18,638	20,314	21,995	23,670	25,330
				A	23.1	24.5	26.1	27.8	29.6	31.5	33.4	35.4	37.4
		110	C	51,613	61,973	73,148	85,254	98,408	112,724	128,320	145,310	163,811	
			P	12,388	13,839	15,327	16,841	18,370	19,905	21,436	22,953	24,445	
			A	23.3	24.6	26.1	27.6	29.3	31.0	32.8	34.5	36.3	
		100	C	58,803	69,896	81,964	95,121	109,484	125,167	142,289	160,963	181,307	
			P	12,454	13,796	15,164	16,549	17,942	19,332	20,708	22,062	23,382	
			A	23.3	24.5	25.9	27.3	28.8	30.3	31.9	33.5	35.1	
INBBX3400L6C	6GE34Y-2NU	34	130	C	49,880	60,330	71,471	83,444	96,392	110,456	125,780	142,506	160,775
				P	16,170	18,139	20,186	22,298	24,464	26,671	28,908	31,164	33,424
				A	26.9	29.0	31.4	33.8	36.4	39.1	41.9	44.7	47.6
			120	C	58,947	70,427	82,782	96,155	110,687	126,521	143,798	162,662	183,255
				P	16,358	18,192	20,092	22,046	24,042	26,067	28,111	30,160	32,204
				A	27.1	29.1	31.3	33.5	35.9	38.4	40.9	43.5	46.1
		110	C	67,535	80,032	93,590	108,350	124,454	142,044	161,264	182,255	205,159	
			P	16,343	18,044	19,800	21,598	23,425	25,271	27,123	28,969	30,797	
			A	27.1	28.9	30.9	33.0	35.1	37.4	39.7	42.0	44.3	
		100	C	75,825	89,328	104,076	120,211	137,875	157,210	178,360	201,465	226,668	
			P	16,156	17,727	19,340	20,984	22,645	24,313	25,975	27,619	29,234	
			A	26.9	28.6	30.4	32.3	34.2	36.2	38.2	40.3	42.3	
INBBX4400L6C	6FE44Y-2NU	44	130	C	54,966	68,197	82,175	97,075	113,070	130,335	149,043	169,368	191,484
				P	18,626	21,065	23,577	26,146	28,757	31,398	34,053	36,708	39,348
				A	37.0	39.3	41.7	44.3	47.1	49.9	52.8	55.7	58.7
			120	C	66,346	80,750	96,138	112,686	130,567	149,955	171,023	193,946	218,898
				P	19,152	21,442	23,792	26,188	28,614	31,057	33,502	35,934	38,340
				A	37.5	39.7	42.0	44.4	46.9	49.5	52.2	54.9	57.6
		110	C	77,419	92,959	109,722	127,882	147,612	169,087	192,480	217,965	245,717	
			P	19,458	21,593	23,776	25,991	28,225	30,463	32,692	34,895	37,061	
			A	37.8	39.8	41.9	44.1	46.5	48.8	51.2	53.7	56.1	
		100	C	88,204	104,845	122,946	142,682	164,225	187,751	213,433	241,445	271,961	
			P	19,557	21,530	23,538	25,567	27,602	29,629	31,634	33,602	35,520	
			A	37.9	39.7	41.7	43.7	45.8	47.9	50.1	52.2	54.4	

MBBX
R404A
460V-3F-60HZ

Modelo	Compresor	H.P	TSC	TSE °F	C=Capacidad (BTU/h) P=Potencia (KWatt) A=Corriente (Amp)							
					5	10	15	20	25	30	35	40
INBEX0500M6C	5	06DM313	130	C	17,493.00	21,147.00	25,097.00	29,374.00	34,012.00	39,044.00	44,503.00	50,422.00
				P	3.60	3.90	4.30	4.60	4.90	5.20	5.50	5.80
				A	11.2	12.1	13.0	14.0	14.9	15.9	16.8	17.8
			120	C	23,491.00	27,942.00	32,765.00	37,997.00	43,676.00	49,841.00	56,531.00	63,785.00
				P	3.60	3.90	4.20	4.50	4.80	5.00	5.20	5.40
				A	11.3	12.0	12.8	13.5	14.3	15.1	15.8	16.6
	110	C	25,612.00	30,088.00	34,940.00	40,202.00	45,907.00	52,087.00	58,775.00	66,004.00		
		P	3.60	3.80	4.10	4.30	4.50	4.70	4.90	5.10		
		A	11.2	11.8	12.4	13.0	13.6	14.2	14.8	15.4		
	100	C	29,634.00	34,491.00	39,766.00	45,491.00	51,700.00	58,424.00	65,698.00	73,553.00		
		P	3.50	3.70	3.90	4.10	4.30	4.40	4.60	4.70		
		A	11.0	11.5	12.0	12.5	12.9	13.4	13.8	14.2		
INBEX0650M6C	5	06DM316	130	C	24,499.00	28,791.00	33,489.00	38,639.00	44,307.00	-	-	-
				P	4.90	5.30	5.80	6.10	6.50	-	-	-
				A	14.5	15.8	17.0	18.2	19.4	-	-	-
			120	C	29,119.00	33,996.00	39,347.00	45,230.00	51,701.00	-	-	-
				P	4.90	5.30	5.70	6.00	6.30	-	-	-
				A	14.8	15.8	16.8	17.7	18.6	-	-	-
	110	C	33,780.00	39,243.00	45,253.00	51,868.00	59,142.00	-	-	-		
		P	4.90	5.20	5.50	5.80	6.00	-	-	-		
		A	14.7	15.5	16.3	17.0	17.7	-	-	-		
	100	C	38,543.00	44,592.00	51,263.00	58,610.00	66,690.00	-	-	-		
		P	4.80	5.00	5.30	5.50	5.60	-	-	-		
		A	14.4	15.0	15.6	16.1	16.6	-	-	-		
INBEX0750M6C	6.5	06DA818	130	C	27,666.00	32,686.00	38,182.00	44,194.00	50,762.00	57,926.00	65,725.00	74,199.00
				P	6.20	6.70	7.20	7.60	8.00	8.40	8.80	9.10
				A	18.3	19.5	20.8	22.0	23.2	24.3	25.4	26.4
			120	C	33,662.00	39,275.00	45,398.00	52,073.00	59,338.00	67,234.00	75,799.00	85,075.00
				P	6.10	6.50	6.90	7.30	7.60	7.90	8.20	8.40
				A	18.1	19.1	20.0	20.9	21.8	22.6	23.4	24.0
	110	C	39,212.00	45,374.00	52,083.00	59,378.00	67,299.00	75,885.00	85,176.00	95,211.00		
		P	5.90	6.30	6.60	6.90	7.10	7.30	7.50	7.60		
		A	17.8	18.5	19.2	19.9	20.5	21.0	21.5	21.8		
	100	C	44,575.00	51,244.00	58,495.00	66,368.00	74,901.00	84,135.00	94,109.00	104,863.00		
		P	5.70	6.00	6.20	6.40	6.60	6.70	6.80	6.80		
		A	17.3	17.9	18.4	18.8	19.2	19.5	19.7	19.8		
INBEX0800M6C	7.5	06DA825	130	C	34,367.00	40,844.00	47,974.00	55,813.00	64,417.00	73,845.00	84,152.00	95,397.00
				P	8.00	8.70	9.30	9.90	10.40	10.90	11.30	11.70
				A	23.6	25.2	26.8	28.3	29.7	31.1	32.4	33.5
			120	C	42,293.00	49,596.00	57,604.00	66,374.00	75,962.00	86,426.00	97,822.00	110,207.00
				P	7.90	8.40	8.90	9.40	9.90	10.20	10.60	10.90
				A	23.4	24.7	26.0	27.2	28.3	29.3	30.2	31.0
	110	C	49,574.00	57,652.00	66,488.00	76,140.00	86,662.00	98,113.00	110,549.00	124,027.00		
		P	7.70	8.10	8.50	8.90	9.20	9.50	9.70	9.90		
		A	22.9	23.9	24.9	25.8	26.6	27.4	27.9	28.4		
	100	C	56,655.00	65,458.00	75,073.00	85,555.00	96,962.00	109,351.00	122,777.00	137,297.00		
		P	7.30	7.70	8.00	8.30	8.50	8.70	8.80	8.90		
		A	22.1	23.0	23.7	24.4	24.9	25.4	25.7	25.8		

Modelo	Compresor	H.P	TSC		TSE °F C=Capacidad (BTU/h) P=Potencia (KWatt) A=Corriente (Amp)					30	35	40
					5	10	15	20	25			
INBEX1000M6C	10	06DA328	130	C	45,857.00	53,022.00	60,926.00	69,647.00	79,262.00	89,851.00	101,491.00	114,291.00
				P	10.30	10.90	11.50	12.00	12.60	13.10	13.50	13.90
				A	29.7	31.2	32.8	34.3	35.7	37.0	38.2	39.3
			120	C	54,516.00	62,620.00	71,541.00	81,358.00	91,149.00	103,991.00	116,963.00	131,143.00
				P	9.90	10.40	10.90	11.40	11.80	12.20	12.60	12.90
				A	28.6	29.9	31.2	32.5	33.6	34.6	35.5	36.3
			110	C	62,177.00	71,186.00	81,093.00	91,974.00	103,908.00	116,972.00	131,245.00	146,804.00
				P	9.40	9.90	10.30	10.70	11.00	11.30	11.50	11.70
				A	27.5	28.6	29.7	30.7	31.5	32.2	32.8	33.3
			100	C	69,542.00	79,425.00	90,284.00	102,196.00	115,240.00	129,494.00	145,036.00	161,943.00
				P	8.90	9.30	9.60	9.90	10.10	10.30	10.40	10.50
				A	26.2	27.2	28.0	28.7	29.3	29.8	30.1	30.2
INBEX1500M6C	15	06DA537	130	C	63,395.00	75,177.00	85,895.00	97,631.00	110,467.00	124,488.00	139,774.00	156,410.00
				P	14.10	15.00	15.90	16.80	17.60	18.30	19.00	19.60
				A	40.8	43.1	45.3	47.5	49.5	51.5	53.3	55.0
			120	C	77,016.00	87,948.00	99,891.00	112,928.00	127,142.00	142,614.00	159,428.00	177,665.00
				P	13.50	14.30	15.00	15.70	16.40	17.00	17.50	17.90
				A	39.2	41.1	43.0	44.7	46.3	47.8	49.2	50.4
			110	C	87,190.00	99,199.00	112,295.00	126,561.00	142,080.00	158,933.00	177,203.00	196,973.00
				P	12.80	13.40	14.00	14.60	15.10	15.50	15.90	16.20
				A	37.5	39.1	40.6	41.9	43.2	44.2	45.1	45.9
			100	C	96,964.00	109,775.00	123,951.00	139,374.00	156,124.00	174,286.00	193,940.00	215,169.00
				P	12.00	12.50	13.00	13.40	13.80	14.10	14.30	14.40
				A	35.6	36.9	38.1	39.1	39.9	40.6	41.1	41.4
INBEX2500M6C	20	06EA550	130	C	82,204.00	95,159.00	109,460.00	125,249.00	142,666.00	161,854.00	182,955.00	206,112.00
				P	18.90	20.00	21.20	22.20	23.30	24.30	25.20	26.00
				A	53.2	56.1	59.0	61.9	64.6	67.3	69.8	72.2
			120	C	97,683.00	112,344.00	128,494.00	146,275.00	165,828.00	187,294.00	210,816.00	236,535.00
				P	18.20	19.20	20.20	21.10	22.00	22.80	23.50	24.10
				A	51.6	54.1	56.5	58.8	61.1	63.2	65.1	66.8
			110	C	111,628.00	127,940.00	145,885.00	165,605.00	187,240.00	210,931.00	236,822.00	265,053.00
				P	17.50	18.30	19.20	19.90	20.60	21.20	21.70	22.10
				A	49.9	52.0	53.9	55.8	57.5	59.0	60.4	61.5
			100	C	125,206.00	143,116.00	162,802.00	184,402.00	208,058.00	233,910.00	262,096.00	292,755.00
				P	16.60	17.40	18.00	18.60	19.10	19.50	19.90	20.10
				A	47.9	49.6	51.2	52.6	53.8	54.9	55.7	56.2
INBEX3000M6C	25	06EA565	130	C	96,363.00	115,219.00	135,427.00	157,141.00	180,514.00	205,698.00	232,846.00	262,111.00
				P	18.50	20.70	22.80	24.90	26.80	28.70	30.50	32.10
				A	54.1	60.3	66.1	71.6	76.9	81.8	86.4	90.6
			120	C	117,322.00	138,126.00	160,474.00	184,518.00	210,411.00	238,306.00	268,356.00	300,713.00
				P	19.20	21.10	22.90	24.70	26.40	27.90	29.40	30.70
				A	56.1	61.3	66.4	71.1	75.5	79.6	83.3	86.7
			110	C	137,641.00	160,275.00	184,644.00	210,900.00	239,195.00	269,682.00	302,515.00	337,846.00
				P	19.40	21.00	22.60	24.10	25.40	26.70	27.90	28.90
				A	56.8	61.3	65.5	69.4	73.0	76.3	79.3	81.9
			100	C	157,484.00	181,831.00	208,102.00	236,451.00	267,030.00	299,992.00	335,489.00	373,676.00
				P	19.10	20.50	21.80	23.00	24.20	25.10	26.00	26.70
				A	56.4	60.2	63.6	66.8	69.7	72.2	74.4	76.3

INBEX

R404A

208-230V-3F-60HZ

Modelo	Compresor	H.P	TSC		TSE °F C=Capacidad (BTU/h) P=Potencia (KWatt) A=Corriente (Amp)							
					5	10	15	20	25	30	35	40
INBEX3500M6C	30	06EA575	130	C	123,965.00	143,214.00	164,150.00	186,990.00	211,953.00	239,257.00	269,122.00	301,765.00
				P	22.70	24.70	26.70	28.70	30.70	32.70	34.60	36.50
				A	65.6	70.5	75.5	80.7	85.8	91.0	96.2	101.4
			120	C	144,286.00	166,005.00	189,691.00	215,563.00	243,840.00	274,739.00	308,480.00	345,281.00
				P	22.80	24.60	26.50	28.30	30.10	31.90	33.60	35.20
				A	65.5	70.1	74.7	79.3	83.9	88.5	92.9	97.3
			110	C	164,370.00	188,511.00	214,902.00	243,760.00	275,304.00	309,752.00	347,324.00	388,236.00
				P	22.50	24.20	25.90	27.50	29.10	30.60	32.10	33.40
				A	65.0	69.1	73.3	77.4	81.4	85.3	89.1	92.7
			100	C	184,484.00	211,003.00	240,052.00	271,850.00	306,615.00	344,566.00	385,921.00	430,900.00
				P	21.90	23.40	24.90	26.30	27.70	28.90	30.10	31.20
				A	64.0	67.7	71.4	74.9	78.3	81.5	84.6	87.4
INBEX4000M6C	40	06EA599	130	C	176,819.00	197,500.00	219,620.00	243,430.00	269,182.00	297,130.00	327,524.00	360,616.00
				P	34.10	37.10	39.80	42.40	45.10	47.90	50.90	54.20
				A	108.2	110.7	114.1	118.6	124.2	131.0	139.2	148.8
			120	C	219,605.00	242,339.00	266,716.00	292,988.00	321,407.00	352,225.00	385,693.00	422,065.00
				P	35.20	37.50	39.60	41.60	43.60	45.60	47.90	50.40
				A	107.6	110.0	113.2	117.3	122.5	128.8	136.4	145.3
			110	C	256,867.00	281,455.00	307,889.00	336,423.00	367,308.00	400,796.00	437,140.00	476,590.00
				P	34.60	36.50	38.00	39.50	40.80	42.30	43.90	45.80
				A	104.7	107.0	110.1	113.9	118.8	124.6	131.6	139.9
			100	C	289,042.00	315,283.00	343,575.00	374,170.00	407,321.00	443,279.00	482,297.00	524,626.00
				P	32.90	34.30	35.50	36.50	37.40	38.40	39.40	40.70
				A	100.0	102.3	105.3	109.0	113.5	119.0	125.5	133.2

Modelo	Compresor	H.P	TSC	TSE°F ° C=Capacidad (BTU/h) P=Potencia (KWatt) A=Corriente (Amp)								
				5	10	15	20	25	30	35	40	
INBEX0500M6D	5	06DM313	130	C	17,493.00	21,147.00	25,097.00	29,374.00	34,012.00	39,044.00	44,503.00	50,422.00
				P	3.60	3.90	4.30	4.60	4.90	5.20	5.50	5.80
				A	5.6	6.1	6.5	7.0	7.5	8.0	8.4	8.9
			120	C	23,491.00	27,942.00	32,765.00	37,997.00	43,676.00	49,841.00	56,531.00	63,785.00
				P	3.60	3.90	4.20	4.50	4.80	5.00	5.20	5.40
				A	5.7	6.0	6.4	6.8	7.2	7.6	7.9	8.3
		110	C	25,612.00	30,088.00	34,940.00	40,202.00	45,907.00	52,087.00	58,775.00	66,004.00	
			P	3.60	3.80	4.10	4.30	4.50	4.70	4.90	5.10	
			A	5.6	5.9	6.2	6.5	6.8	7.1	7.4	7.7	
		100	C	29,634.00	34,491.00	39,766.00	45,491.00	51,700.00	58,424.00	65,698.00	73,553.00	
			P	3.50	3.70	3.90	4.10	4.30	4.40	4.60	4.70	
			A	5.5	5.8	6.0	6.3	6.5	6.7	6.9	7.1	
INBEX0650M6D	5	06DM316	130	C	24,499.00	28,791.00	33,489.00	38,639.00	44,307.00	-	-	-
				P	4.90	5.30	5.80	6.10	6.50	-	-	-
				A	7.3	7.9	8.5	9.1	9.7	-	-	-
			120	C	29,119.00	33,996.00	39,347.00	45,230.00	51,701.00	-	-	-
				P	4.90	5.30	5.70	6.00	6.30	-	-	-
				A	7.4	7.9	8.4	8.9	9.3	-	-	-
		110	C	33,780.00	39,243.00	45,253.00	51,868.00	59,142.00	-	-	-	
			P	4.90	5.20	5.50	5.80	6.00	-	-	-	
			A	7.4	7.8	8.2	8.5	8.9	-	-	-	
		100	C	38,543.00	44,592.00	51,263.00	58,610.00	66,690.00	-	-	-	
			P	4.80	5.00	5.30	5.50	5.60	-	-	-	
			A	7.2	7.5	7.8	8.1	8.3	-	-	-	
INBEX0750M6D	6.5	06DA818	130	C	27,666.00	32,686.00	38,182.00	44,194.00	50,762.00	57,926.00	65,725.00	74,199.00
				P	6.20	6.70	7.20	7.60	8.00	8.40	8.80	9.10
				A	9.2	9.8	10.4	11.0	11.6	12.2	12.7	13.2
			120	C	33,662.00	39,275.00	45,398.00	52,073.00	59,338.00	67,234.00	75,799.00	85,075.00
				P	6.10	6.50	6.90	7.30	7.60	7.90	8.20	8.40
				A	9.1	9.6	10.0	10.5	10.9	11.3	11.7	12.0
		110	C	39,212.00	45,374.00	52,083.00	59,378.00	67,299.00	75,885.00	85,176.00	95,211.00	
			P	5.90	6.30	6.60	6.90	7.10	7.30	7.50	7.60	
			A	8.9	9.3	9.6	10.0	10.3	10.5	10.8	10.9	
		100	C	44,575.00	51,244.00	58,495.00	66,368.00	74,901.00	84,135.00	94,109.00	104,863.00	
			P	5.70	6.00	6.20	6.40	6.60	6.70	6.80	6.80	
			A	8.7	9.0	9.2	9.4	9.6	9.8	9.9	9.9	
INBEX0800M6D	7.5	06DA825	130	C	34,367.00	40,844.00	47,974.00	55,813.00	64,417.00	73,845.00	84,152.00	95,397.00
				P	8.00	8.70	9.30	9.90	10.40	10.90	11.30	11.70
				A	11.8	12.6	13.4	14.2	14.9	15.6	16.2	16.8
			120	C	42,293.00	49,596.00	57,604.00	66,374.00	75,962.00	86,426.00	97,822.00	110,207.00
				P	7.90	8.40	8.90	9.40	9.90	10.20	10.60	10.90
				A	11.7	12.4	13.0	13.6	14.2	14.7	15.1	15.5
		110	C	49,574.00	57,652.00	66,488.00	76,140.00	86,662.00	98,113.00	110,549.00	124,027.00	
			P	7.70	8.10	8.50	8.90	9.20	9.50	9.70	9.90	
			A	11.5	12.0	12.5	12.9	13.3	13.7	14.0	14.2	
		100	C	56,655.00	65,458.00	75,073.00	85,555.00	96,962.00	109,351.00	122,777.00	137,297.00	
			P	7.30	7.70	8.00	8.30	8.50	8.70	8.80	8.90	
			A	11.1	11.5	11.9	12.2	12.5	12.7	12.9	12.9	

INBEX

R404A

460V-3F-60Hz

Modelo	Compresor	H.P	TSC	TSE°F ° C=Capacidad (BTU/h) P=Potencia (KWatt) A=Corriente (Amp)								
				5	10	15	20	25	30	35	40	
INBEX1000M6D	10	06DA328	130	C	45,857.00	53,022.00	60,926.00	69,647.00	79,262.00	89,851.00	101,491.00	114,291.00
				P	10.30	10.90	11.50	12.00	12.60	13.10	13.50	13.90
				A	14.9	15.6	16.4	17.2	17.9	18.5	19.1	19.7
			120	C	54,516.00	62,620.00	71,541.00	81,358.00	91,149.00	103,991.00	116,963.00	131,143.00
				P	9.90	10.40	10.90	11.40	11.80	12.20	12.60	12.90
				A	14.3	15.0	15.6	16.3	16.8	17.3	17.8	18.2
	110	C	62,177.00	71,186.00	81,093.00	91,974.00	103,908.00	116,972.00	131,245.00	146,804.00		
		P	9.40	9.90	10.30	10.70	11.00	11.30	11.50	11.70		
		A	13.8	14.3	14.9	15.4	15.8	16.1	16.4	16.7		
	100	C	69,542.00	79,425.00	90,284.00	102,196.00	115,240.00	129,494.00	145,036.00	161,943.00		
		P	8.90	9.30	9.60	9.90	10.10	10.30	10.40	10.50		
		A	13.1	13.6	14.0	14.4	14.7	14.9	15.1	15.1		
INBEX1500M6D	15	06DA537	130	C	63,395.00	75,177.00	85,895.00	97,631.00	110,467.00	124,488.00	139,774.00	156,410.00
				P	14.10	15.00	15.90	16.80	17.60	18.30	19.00	19.60
				A	20.4	21.6	22.7	23.8	24.8	25.8	26.7	27.5
			120	C	77,016.00	87,948.00	99,891.00	112,928.00	127,142.00	142,614.00	159,428.00	177,665.00
				P	13.50	14.30	15.00	15.70	16.40	17.00	17.50	17.90
				A	19.6	20.6	21.5	22.4	23.2	23.9	24.6	25.2
	110	C	87,190.00	99,199.00	112,295.00	126,561.00	142,080.00	158,933.00	177,203.00	196,973.00		
		P	12.80	13.40	14.00	14.60	15.10	15.50	15.90	16.20		
		A	18.8	19.6	20.3	21.0	21.6	22.1	22.6	23.0		
	100	C	96,964.00	109,775.00	123,951.00	139,374.00	156,124.00	174,286.00	193,940.00	215,169.00		
		P	12.00	12.50	13.00	13.40	13.80	14.10	14.30	14.40		
		A	17.8	18.5	19.1	19.6	20.0	20.3	20.6	20.7		
INBEX2500M6D	20	06EA550	130	C	82,204.00	95,159.00	109,460.00	125,249.00	142,666.00	161,854.00	182,955.00	206,112.00
				P	18.90	20.00	21.20	22.20	23.30	24.30	25.20	26.00
				A	26.6	28.1	29.5	31.0	32.3	33.7	34.9	36.1
			120	C	97,683.00	112,344.00	128,494.00	146,275.00	165,828.00	187,294.00	210,816.00	236,535.00
				P	18.20	19.20	20.20	21.10	22.00	22.80	23.50	24.10
				A	25.8	27.1	28.3	29.4	30.6	31.6	32.6	33.4
	110	C	111,628.00	127,940.00	145,885.00	165,605.00	187,240.00	210,931.00	236,822.00	265,053.00		
		P	17.50	18.30	19.20	19.90	20.60	21.20	21.70	22.10		
		A	25.0	26.0	27.0	27.9	28.8	29.5	30.2	30.8		
	100	C	125,206.00	143,116.00	162,802.00	184,402.00	208,058.00	233,910.00	262,096.00	292,755.00		
		P	16.60	17.40	18.00	18.60	19.10	19.50	19.90	20.10		
		A	24.0	24.8	25.6	26.3	26.9	27.5	27.9	28.1		
INBEX3000M6D	25	06EA565	130	C	96,363.00	115,219.00	135,427.00	157,141.00	180,514.00	205,698.00	232,846.00	262,111.00
				P	18.50	20.70	22.80	24.90	26.80	28.70	30.50	32.10
				A	27.1	30.2	33.1	35.8	38.5	40.9	43.2	45.3
			120	C	117,322.00	138,126.00	160,474.00	184,518.00	210,411.00	238,306.00	268,356.00	300,713.00
				P	19.20	21.10	22.90	24.70	26.40	27.90	29.40	30.70
				A	28.1	30.7	33.2	35.6	37.8	39.8	41.7	43.4
	110	C	137,641.00	160,275.00	184,644.00	210,900.00	239,195.00	269,682.00	302,515.00	337,846.00		
		P	19.40	21.00	22.60	24.10	25.40	26.70	27.90	28.90		
		A	28.4	30.7	32.8	34.7	36.5	38.2	39.7	41.0		
	100	C	157,484.00	181,831.00	208,102.00	236,451.00	267,030.00	299,992.00	335,489.00	373,676.00		
		P	19.10	20.50	21.80	23.00	24.20	25.10	26.00	26.70		
		A	28.2	30.1	31.8	33.4	34.9	36.1	37.2	38.2		

Modelo	Compresor	H.P	TSC		TSE°F ° C=Capacidad (BTU/h) P=Potencia (KWatt) A=Corriente (Amp)							
					5	10	15	20	25	30	35	40
INBEX3500M6D	30	06EA575	130	C	123,965.00	143,214.00	164,150.00	186,990.00	211,953.00	239,257.00	269,122.00	301,765.00
				P	22.70	24.70	26.70	28.70	30.70	32.70	34.60	36.50
				A	32.8	35.3	37.8	40.4	42.9	45.5	48.1	50.7
			120	C	144,286.00	166,005.00	189,691.00	215,563.00	243,840.00	274,739.00	308,480.00	345,281.00
				P	22.80	24.60	26.50	28.30	30.10	31.90	33.60	35.20
				A	32.8	35.1	37.4	39.7	42.0	44.3	46.5	48.7
			110	C	164,370.00	188,511.00	214,902.00	243,760.00	275,304.00	309,752.00	347,324.00	388,236.00
				P	22.50	24.20	25.90	27.50	29.10	30.60	32.10	33.40
				A	32.5	34.6	36.7	38.7	40.7	42.7	44.6	46.4
			100	C	184,484.00	211,003.00	240,052.00	271,850.00	306,615.00	344,566.00	385,921.00	430,900.00
				P	21.90	23.40	24.90	26.30	27.70	28.90	30.10	31.20
				A	32.0	33.9	35.7	37.5	39.2	40.8	42.3	43.7
INBEX4000M6D	40	06EA599	130	C	176,819.00	197,500.00	219,620.00	243,430.00	269,182.00	297,130.00	327,524.00	360,616.00
				P	34.10	37.10	39.80	42.40	45.10	47.90	50.90	54.20
				A	54.1	55.4	57.1	59.3	62.1	65.5	69.6	74.4
			120	C	219,605.00	242,339.00	266,716.00	292,988.00	321,407.00	352,225.00	385,693.00	422,065.00
				P	35.20	37.50	39.60	41.60	43.60	45.60	47.90	50.40
				A	53.8	55.0	56.6	58.7	61.3	64.4	68.2	72.7
			110	C	256,867.00	281,455.00	307,889.00	336,423.00	367,308.00	400,796.00	437,140.00	476,590.00
				P	34.60	36.50	38.00	39.50	40.80	42.30	43.90	45.80
				A	52.4	53.5	55.1	57.0	59.4	62.3	65.8	70.0
			100	C	289,042.00	315,283.00	343,575.00	374,170.00	407,321.00	443,279.00	482,297.00	524,626.00
				P	32.90	34.30	35.50	36.50	37.40	38.40	39.40	40.70
				A	50.0	51.2	52.7	54.5	56.8	59.5	62.8	66.6

INBEX

R404A

460V-3F-60HZ

Modelo	Compresor	H.P	TSC	TSE°F ° C=Capacidad (BTU/h) P=Potencia (KWatt) A=Corriente (Amp)									
				-40	-35	-30	-25	-20	-15	-10	-5	0	
INBEX0300L6C	5	06DR316	130	C	5,833.00	7,653.00	9,664.00	11,887.00	14,340.00	17,044.00	20,018.00	23,282.00	29,679.00
				P	2.30	2.90	3.20	3.50	3.80	4.10	4.70	5.10	5.40
				A	8.6	10.0	10.8	11.5	12.2	12.9	14.4	15.2	16.0
			120	C	7,391.00	9,404.00	11,630.00	14,090.00	16,308.00	19,790.00	23,069.00	26,660.00	30,584.00
				P	2.50	2.70	3.10	3.50	3.90	4.30	4.60	4.90	5.20
				A	8.9	9.7	10.7	11.6	12.6	13.5	14.1	14.8	15.5
		110	C	8,912.00	11,108.00	13,540.00	16,228.00	19,192.00	22,452.00	26,026.00	29,936.00	34,201.00	
			P	2.50	2.90	3.20	3.50	3.80	4.10	4.40	4.70	5.00	
			A	9.1	9.9	10.7	11.5	12.3	13.0	13.7	14.4	15.0	
		100	C	10,418.00	12,787.00	15,415.00	18,321.00	21,526.00	25,050.00	28,911.00	33,130.00	37,726.00	
			P	2.60	2.80	3.10	3.40	3.70	4.00	4.20	4.50	4.70	
			A	9.1	9.9	10.6	11.3	12.0	12.7	13.3	12.8	14.4	
INBEX0400L6C	5	06DR718	130	C	8,313.00	10,496.00	12,878.00	15,478.00	18,320.00	21,642.00	25,063.00	28,791.00	32,847.00
				P	2.90	3.40	3.90	4.30	4.80	5.20	5.70	6.10	6.50
				A	13.8	13.2	13.0	13.3	13.9	14.9	16.3	18.0	19.9
			120	C	10,223.00	12,626.00	15,253.00	18,123.00	21,259.00	24,681.00	28,410.00	32,469.00	36,877.00
				P	3.00	3.50	3.90	4.30	4.70	5.10	5.50	5.90	6.30
				A	13.9	13.3	13.0	13.2	13.7	14.5	15.7	17.1	18.7
		110	C	11,964.00	14,553.00	17,378.00	20,488.00	23,875.00	27,571.00	31,597.00	35,974.00	40,722.00	
			P	3.10	3.50	3.80	4.20	4.60	4.90	5.30	5.60	6.00	
			A	13.9	13.3	13.0	13.1	13.5	14.2	15.1	16.2	17.5	
		100	C	13,644.00	16,406.00	19,436.00	22,753.00	26,380.00	30,337.00	34,646.00	39,328.00	44,405.00	
			P	3.10	3.50	3.80	4.10	4.40	4.80	5.10	5.40	5.70	
			A	13.9	13.3	13.0	13.0	13.3	13.8	14.5	15.4	16.4	
INBEX0500L6C	6.5	06DR820	130	C	8,696.00	11,112.00	13,780.00	16,727.00	19,977.00	23,555.00	27,487.00	31,798.00	36,512.00
				P	3.20	3.70	4.20	4.70	5.10	5.60	6.10	6.60	7.10
				A	12.5	13.5	14.6	15.6	16.7	17.8	18.9	20.0	21.2
			120	C	10,711.00	13,382.00	16,335.00	19,594.00	23,185.00	27,133.00	31,463.00	36,200.00	41,370.00
				P	3.30	3.70	4.20	4.60	5.10	5.50	6.00	6.40	6.80
				A	12.7	13.7	14.6	15.6	16.6	17.5	18.5	19.5	20.5
		110	C	12,677.00	15,589.00	18,811.00	22,369.00	26,287.00	30,590.00	35,305.00	40,455.00	46,066.00	
			P	3.40	3.80	4.20	4.60	5.00	5.40	5.80	6.10	6.50	
			A	12.9	13.8	14.6	15.5	16.3	17.2	18.1	18.9	19.8	
		100	C	14,618.00	17,757.00	21,235.00	25,076.00	29,308.00	33,953.00	39,038.00	44,587.00	50,626.00	
			P	3.40	3.80	4.10	4.50	4.80	5.20	5.50	5.90	6.20	
			A	12.9	13.7	14.5	15.3	16.0	16.8	17.5	18.3	19.0	
INBEX0600L6C	6.5	06DR725	130	C	7,725.00	10,499.00	13,560.00	16,936.00	20,653.00	24,741.00	29,226.00	34,137.00	39,501.00
				P	2.90	3.50	4.10	4.70	5.30	5.90	6.50	7.10	7.70
				A	11.9	13.2	14.5	15.8	17.1	18.4	19.8	21.3	22.8
			120	C	10,125.00	13,187.00	16,569.00	20,296.00	24,397.00	28,900.00	33,832.00	39,222.00	45,096.00
				P	3.10	3.70	4.30	4.80	5.40	5.90	6.50	7.00	7.60
				A	12.4	13.6	14.8	16.0	17.2	18.4	19.6	20.9	22.3
		110	C	12,499.00	15,833.00	19,518.00	23,580.00	28,048.00	32,950.00	38,312.00	44,164.00	50,531.00	
			P	3.30	3.80	4.30	4.90	5.40	5.90	6.30	6.80	7.30	
			A	12.8	13.9	15.0	16.0	17.1	18.2	19.3	20.5	21.7	
		100	C	14,865.00	18,453.00	22,424.00	26,804.00	31,622.00	36,905.00	42,681.00	48,977.00	55,822.00	
			P	3.50	3.90	4.40	4.80	5.30	5.70	6.20	6.60	7.00	
			A	13.1	14.1	15.0	16.0	17.0	17.9	18.9	19.9	21.0	

Modelo	Compresor	H.P	TSC	TSE°F ° C=Capacidad (BTU/h) P=Potencia (KWatt) A=Corriente (Amp)										
				-40	-35	-30	-25	-20	-15	-10	-5	0		
INBEX0750L6C	7.5	06DR228	130	C	10,588.00	14,471.00	18,607.00	23,030.00	27,772.00	32,864.00	38,339.00	44,229.00	50,566.00	
				P	3.60	4.50	5.30	6.10	6.90	7.70	8.40	9.10	9.80	
				A	14.6	17.2	19.7	21.9	24.0	26.0	27.7	29.3	30.8	
			120	C	13,980.00	18,102.00	22,514.00	27,250.00	32,341.00	37,819.00	43,717.00	50,066.00	56,899.00	
				P	4.00	4.80	5.50	6.20	6.90	7.60	8.30	8.90	9.40	
				A	15.7	18.1	20.3	22.3	24.1	25.8	27.4	28.7	30.0	
			110	C	17,163.00	21,504.00	26,173.00	31,202.00	36,622.00	42,467.00	48,768.00	55,557.00	62,866.00	
				P	4.30	5.00	5.60	6.30	6.90	7.40	8.00	8.50	9.00	
				A	16.5	18.6	20.6	22.3	23.9	25.4	26.7	27.9	29.0	
			100	C	20,176.00	24,716.00	29,621.00	34,922.00	40,653.00	46,844.00	53,528.00	60,738.00	68,504.00	
				P	4.50	5.10	5.60	6.20	6.70	7.20	7.60	8.10	8.40	
				A	17.1	18.9	20.6	22.1	23.5	24.8	25.9	26.9	27.8	
INBEX1000L6C	10	06DR337	130	C	20,531.00	24,168.00	28,173.00	32,613.00	37,552.00	43,055.00	49,188.00	56,015.00	63,603.00	
				P	6.60	7.30	8.10	8.80	9.70	10.50	11.40	12.30	13.20	
				A	21.5	23.1	24.8	26.6	28.6	30.8	33.1	35.6	38.2	
			120	C	23,642.00	27,719.00	32,241.00	37,272.00	42,876.00	49,120.00	56,067.00	63,783.00	72,333.00	
				P	6.50	7.20	7.90	8.70	9.50	10.30	11.10	11.90	12.80	
				A	21.4	22.9	24.5	26.3	28.1	30.1	32.2	34.5	36.9	
			110	C	26,830.00	31,354.00	36,397.00	42,023.00	48,298.00	55,287.00	63,054.00	71,665.00	81,184.00	
				P	6.50	7.10	7.80	8.50	9.20	10.00	10.70	11.50	12.30	
				A	21.1	22.6	24.2	25.8	27.5	29.4	31.3	33.3	35.5	
			100	C	30,095.00	35,070.00	40,639.00	46,866.00	53,816.00	61,555.00	70,147.00	79,657.00	90,149.00	
				P	6.40	7.00	7.60	8.30	8.90	9.60	10.30	11.00	11.70	
				A	20.9	22.3	23.8	25.3	26.9	28.5	30.2	32.0	33.9	
INBEX1200L6C	12	06DR541	130	C	20,901.00	25,415.00	30,247.00	35,476.00	41,178.00	47,432.00	54,317.00	61,910.00	70,290.00	
				P	7.90	8.60	9.40	10.20	11.10	12.00	12.90	13.80	14.70	
				A	29.3	30.8	32.4	34.0	35.6	37.3	39.0	40.7	42.5	
			120	C	24,620.00	29,553.00	34,905.00	40,754.00	47,178.00	54,256.00	62,064.00	70,682.00	80,186.00	
				P	7.80	8.50	9.30	10.00	10.80	11.70	12.50	13.40	14.20	
				A	29.2	30.7	32.1	33.7	35.2	36.8	38.3	39.9	41.5	
			110	C	28,500.00	33,842.00	39,704.00	46,165.00	53,302.00	61,193.00	69,915.00	79,548.00	90,169.00	
				P	7.70	8.40	9.10	9.80	10.60	11.30	12.10	12.90	13.70	
				A	29.0	30.4	31.8	33.2	34.7	36.1	37.6	39.0	40.5	
			100	C	32,532.00	38,273.00	44,635.00	51,697.00	59,537.00	68,231.00	77,859.00	88,497.00	100,224.00	
				P	7.60	8.20	8.90	9.60	10.30	11.00	11.70	12.40	13.00	
				A	28.7	30.1	31.4	32.7	34.1	35.4	36.7	38.0	39.3	
INBEX2700L6C	20	06ER475	130	C	24,236.00	34,046.00	44,674.00	56,224.00	68,802.00	82,513.00	97,463.00	113,757.00	131,499.00	
				P	9.70	11.60	13.50	15.60	17.60	19.70	21.90	24.00	26.20	
				A	32.8	37.8	42.9	48.0	53.3	58.6	64.1	69.7	75.5	
			120	C	32,768.00	43,429.00	55,018.00	67,638.00	81,397.00	96,397.00	112,745.00	130,546.00	149,905.00	
				P	10.60	12.40	14.30	16.20	18.10	20.10	22.10	24.10	26.10	
				A	35.3	40.0	44.7	49.5	54.4	59.4	64.4	69.6	74.9	
			110	C	41,082.00	52,540.00	65,036.00	78,673.00	93,557.00	109,793.00	127,487.00	146,742.00	167,664.00	
				P	11.40	13.10	14.80	16.60	18.40	20.20	22.00	23.90	25.70	
				A	37.3	41.7	46.1	50.5	55.0	59.6	64.2	69.0	73.7	
			100	C	49,251.00	61,450.00	74,796.00	89,394.00	105,349.00	122,766.00	141,750.00	162,405.00	184,837.00	
				P	12.00	13.60	15.20	16.80	18.40	20.10	21.70	23.40	25.00	
				A	38.8	42.9	47.0	51.1	55.2	59.4	63.6	67.8	72.2	

INBEX

R404A

208-230V-3F-60HZ

Modelo	Compresor	H.P	TSC		TSE°F ° C=Capacidad (BTU/h) P=Potencia (KWatt) A=Corriente (Amp)								
					-40	-35	-30	-25	-20	-15	-10	-5	0
INBEX3000L6C	30	06ER399	130	C	39,263.00	50,240.00	62,087.00	74,930.00	88,896.00	104,111.00	120,701.00	138,794.00	158,515.00
				P	14.80	17.10	19.40	21.90	24.50	27.10	29.70	32.50	35.20
				A	61.5	66.5	71.5	76.7	82.1	87.8	93.8	100.2	107.0
			120	C	49,251.00	61,268.00	74,300.00	88,473.00	103,914.00	120,749.00	139,104.00	159,106.00	180,881.00
				P	15.70	17.80	20.00	22.40	24.70	27.20	29.70	32.20	34.80
				A	63.4	68.1	72.8	77.7	82.7	88.0	93.5	99.4	105.7
			110	C	59,422.00	72,430.00	86,599.00	102,055.00	118,924.00	137,333.00	157,406.00	179,271.00	203,053.00
				P	16.40	18.40	20.50	22.60	24.90	27.10	29.40	31.80	34.20
				A	64.8	69.2	73.7	78.2	82.9	87.7	92.8	98.2	104.0
			100	C	69,684.00	83,635.00	98,893.00	115,584.00	133,832.00	153,765.00	175,509.00	199,189.00	224,931.00
				P	16.90	18.70	20.70	22.70	24.70	26.80	28.90	31.10	33.30
				A	65.8	69.9	74.1	78.3	82.6	87.0	91.7	96.6	101.9

Modelo	Compresor	H.P	TSC	TSE°F ° C=Capacidad (BTU/h) P=Potencia (KWatt) A=Corriente (Amp)										
				-40	-35	-30	-25	-20	-15	-10	-5	0		
INBEX0300L6D	5	06DR316	130	C	5,833.00	7,653.00	9,664.00	11,887.00	14,340.00	17,044.00	20,018.00	23,282.00	29,679.00	
				P	2.30	2.90	3.20	3.50	3.80	4.10	4.70	5.10	5.40	
				A	4.3	5.0	5.4	5.8	6.1	6.5	7.2	7.6	8.0	
			120	C	7,391.00	9,404.00	11,630.00	14,090.00	16,308.00	19,790.00	23,069.00	26,660.00	30,584.00	
				P	2.50	2.70	3.10	3.50	3.90	4.30	4.60	4.90	5.20	
				A	4.5	4.9	5.4	5.8	6.3	6.8	7.1	7.4	7.8	
		110	C	8,912.00	11,108.00	13,540.00	16,228.00	19,192.00	22,452.00	26,026.00	29,936.00	34,201.00		
			P	2.50	2.90	3.20	3.50	3.80	4.10	4.40	4.70	5.00		
			A	4.6	5.0	5.4	5.8	6.2	6.5	6.9	7.2	7.5		
		100	C	10,418.00	12,787.00	15,415.00	18,321.00	21,526.00	25,050.00	28,911.00	33,130.00	37,726.00		
			P	2.60	2.80	3.10	3.40	3.70	4.00	4.20	4.50	4.70		
			A	4.6	5.0	5.3	5.7	6.0	6.4	6.7	6.4	7.2		
INBEX0400L6D	5	06DR718	130	C	8,313.00	10,496.00	12,878.00	15,478.00	18,320.00	21,642.00	25,063.00	28,791.00	32,847.00	
				P	2.90	3.40	3.90	4.30	4.80	5.20	5.70	6.10	6.50	
				A	6.9	6.6	6.5	6.7	7.0	7.5	8.2	9.0	10.0	
			120	C	10,223.00	12,626.00	15,253.00	18,123.00	21,259.00	24,681.00	28,410.00	32,469.00	36,877.00	
				P	3.00	3.50	3.90	4.30	4.70	5.10	5.50	5.90	6.30	
				A	7.0	6.7	6.5	6.6	6.9	7.3	7.9	8.6	9.4	
		110	C	11,964.00	14,553.00	17,378.00	20,488.00	23,875.00	27,571.00	31,597.00	35,974.00	40,722.00		
			P	3.10	3.50	3.80	4.20	4.60	4.90	5.30	5.60	6.00		
			A	7.0	6.7	6.5	6.6	6.8	7.1	7.6	8.1	8.8		
		100	C	13,644.00	16,406.00	19,436.00	22,753.00	26,380.00	30,337.00	34,646.00	39,328.00	44,405.00		
			P	3.10	3.50	3.80	4.10	4.40	4.80	5.10	5.40	5.70		
			A	7.0	6.7	6.5	6.5	6.7	6.9	7.3	7.7	8.2		
INBEX0500L6D	6.5	06DR820	130	C	8,696.00	11,112.00	13,780.00	16,727.00	19,977.00	23,555.00	27,487.00	31,798.00	36,512.00	
				P	3.20	3.70	4.20	4.70	5.10	5.60	6.10	6.60	7.10	
				A	6.3	6.8	7.3	7.8	8.4	8.9	9.5	10.0	10.6	
			120	C	10,711.00	13,382.00	16,335.00	19,594.00	23,185.00	27,133.00	31,463.00	36,200.00	41,370.00	
				P	3.30	3.70	4.20	4.60	5.10	5.50	6.00	6.40	6.80	
				A	6.4	6.9	7.3	7.8	8.3	8.8	9.3	9.8	10.3	
		110	C	12,677.00	15,589.00	18,811.00	22,369.00	26,287.00	30,590.00	35,305.00	40,455.00	46,066.00		
			P	3.40	3.80	4.20	4.60	5.00	5.40	5.80	6.10	6.50		
			A	6.5	6.9	7.3	7.8	8.2	8.6	9.1	9.5	9.9		
		100	C	14,618.00	17,757.00	21,235.00	25,076.00	29,308.00	33,953.00	39,038.00	44,587.00	50,626.00		
			P	3.40	3.80	4.10	4.50	4.80	5.20	5.50	5.90	6.20		
			A	6.5	6.9	7.3	7.7	8.0	8.4	8.8	9.2	9.5		
INBEX0600L6D	6.5	06DR725	130	C	7,725.00	10,499.00	13,560.00	16,936.00	20,653.00	24,741.00	29,226.00	34,137.00	39,501.00	
				P	2.90	3.50	4.10	4.70	5.30	5.90	6.50	7.10	7.70	
				A	6.0	6.6	7.3	7.9	8.6	9.2	9.9	10.7	11.4	
			120	C	10,125.00	13,187.00	16,569.00	20,296.00	24,397.00	28,900.00	33,832.00	39,222.00	45,096.00	
				P	3.10	3.70	4.30	4.80	5.40	5.90	6.50	7.00	7.60	
				A	6.2	6.8	7.4	8.0	8.6	9.2	9.8	10.5	11.2	
		110	C	12,499.00	15,833.00	19,518.00	23,580.00	28,048.00	32,950.00	38,312.00	44,164.00	50,531.00		
			P	3.30	3.80	4.30	4.90	5.40	5.90	6.30	6.80	7.30		
			A	6.4	7.0	7.5	8.0	8.6	9.1	9.7	10.3	10.9		
		100	C	14,865.00	18,453.00	22,424.00	26,804.00	31,622.00	36,905.00	42,681.00	48,977.00	55,822.00		
			P	3.50	3.90	4.40	4.80	5.30	5.70	6.20	6.60	7.00		
			A	6.6	7.1	7.5	8.0	8.5	9.0	9.5	10.0	10.5		

INBEX

R404A

460V-3F-60HZ

Modelo	Compresor	H.P	TSC	TSE°F ° C=Capacidad (BTU/h) P=Potencia (KWatt) A=Corriente (Amp)										
				-40	-35	-30	-25	-20	-15	-10	-5	0		
INBEX0750L6D	7.5	06DR228	130	C	10,588.00	14,471.00	18,607.00	23,030.00	27,772.00	32,864.00	38,339.00	44,229.00	50,566.00	
				P	3.60	4.50	5.30	6.10	6.90	7.70	8.40	9.10	9.80	
				A	7.3	8.6	9.9	11.0	12.0	13.0	13.9	14.7	15.4	
			120	C	13,980.00	18,102.00	22,514.00	27,250.00	32,341.00	37,819.00	43,717.00	50,066.00	56,899.00	
				P	4.00	4.80	5.50	6.20	6.90	7.60	8.30	8.90	9.40	
				A	7.9	9.1	10.2	11.2	12.1	12.9	13.7	14.4	15.0	
			110	C	17,163.00	21,504.00	26,173.00	31,202.00	36,622.00	42,467.00	48,768.00	55,557.00	62,866.00	
				P	4.30	5.00	5.60	6.30	6.90	7.40	8.00	8.50	9.00	
				A	8.3	9.3	10.3	11.2	12.0	12.7	13.4	14.0	14.5	
			100	C	20,176.00	24,716.00	29,621.00	34,922.00	40,653.00	46,844.00	53,528.00	60,738.00	68,504.00	
				P	4.50	5.10	5.60	6.20	6.70	7.20	7.60	8.10	8.40	
				A	8.6	9.5	10.3	11.1	11.8	12.4	13.0	13.5	13.9	
INBEX1000L6D	10	06DR337	130	C	20,531.00	24,168.00	28,173.00	32,613.00	37,552.00	43,055.00	49,188.00	56,015.00	63,603.00	
				P	6.60	7.30	8.10	8.80	9.70	10.50	11.40	12.30	13.20	
				A	10.8	11.6	12.4	13.3	14.3	15.4	16.6	17.8	19.1	
			120	C	23,642.00	27,719.00	32,241.00	37,272.00	42,876.00	49,120.00	56,067.00	63,783.00	72,333.00	
				P	6.50	7.20	7.90	8.70	9.50	10.30	11.10	11.90	12.80	
				A	10.7	11.5	12.3	13.2	14.1	15.1	16.1	17.3	18.5	
			110	C	26,830.00	31,354.00	36,397.00	42,023.00	48,298.00	55,287.00	63,054.00	71,665.00	81,184.00	
				P	6.50	7.10	7.80	8.50	9.20	10.00	10.70	11.50	12.30	
				A	10.6	11.3	12.1	12.9	13.8	14.7	15.7	16.7	17.8	
			100	C	30,095.00	35,070.00	40,639.00	46,866.00	53,816.00	61,555.00	70,147.00	79,657.00	90,149.00	
				P	6.40	7.00	7.60	8.30	8.90	9.60	10.30	11.00	11.70	
				A	10.5	11.2	11.9	12.7	13.5	14.3	15.1	16.0	17.0	
INBEX1200L6D	12	06DR541	130	C	20,901.00	25,415.00	30,247.00	35,476.00	41,178.00	47,432.00	54,317.00	61,910.00	70,290.00	
				P	7.90	8.60	9.40	10.20	11.10	12.00	12.90	13.80	14.70	
				A	14.7	15.4	16.2	17.0	17.8	18.7	19.5	20.4	21.3	
			120	C	24,620.00	29,553.00	34,905.00	40,754.00	47,178.00	54,256.00	62,064.00	70,682.00	80,186.00	
				P	7.80	8.50	9.30	10.00	10.80	11.70	12.50	13.40	14.20	
				A	14.6	15.4	16.1	16.9	17.6	18.4	19.2	20.0	20.8	
			110	C	28,500.00	33,842.00	39,704.00	46,165.00	53,302.00	61,193.00	69,915.00	79,548.00	90,169.00	
				P	7.70	8.40	9.10	9.80	10.60	11.30	12.10	12.90	13.70	
				A	14.5	15.2	15.9	16.6	17.4	18.1	18.8	19.5	20.3	
			100	C	32,532.00	38,273.00	44,635.00	51,697.00	59,537.00	68,231.00	77,859.00	88,497.00	100,224.00	
				P	7.60	8.20	8.90	9.60	10.30	11.00	11.70	12.40	13.00	
				A	14.4	15.1	15.7	16.4	17.1	17.7	18.4	19.0	19.7	
INBEX2700L6D	20	06ER475	130	C	24,236.00	34,046.00	44,674.00	56,224.00	68,802.00	82,513.00	97,463.00	113,757.00	131,499.00	
				P	9.70	11.60	13.50	15.60	17.60	19.70	21.90	24.00	26.20	
				A	16.4	18.9	21.5	24.0	26.7	29.3	32.1	34.9	37.8	
			120	C	32,768.00	43,429.00	55,018.00	67,638.00	81,397.00	96,397.00	112,745.00	130,546.00	149,905.00	
				P	10.60	12.40	14.30	16.20	18.10	20.10	22.10	24.10	26.10	
				A	17.7	20.0	22.4	24.8	27.2	29.7	32.2	34.8	37.5	
			110	C	41,082.00	52,540.00	65,036.00	78,673.00	93,557.00	109,793.00	127,487.00	146,742.00	167,664.00	
				P	11.40	13.10	14.80	16.60	18.40	20.20	22.00	23.90	25.70	
				A	18.7	20.9	23.1	25.3	27.5	29.8	32.1	34.5	36.9	
			100	C	49,251.00	61,450.00	74,796.00	89,394.00	105,349.00	122,766.00	141,750.00	162,405.00	184,837.00	
				P	12.00	13.60	15.20	16.80	18.40	20.10	21.70	23.40	25.00	
				A	19.4	21.5	23.5	25.6	27.6	29.7	31.8	33.9	36.1	

Modelo	Compresor	H.P	TSC		TSE°F ° C=Capacidad (BTU/h) P=Potencia (KWatt) A=Corriente (Amp)								
					-40	-35	-30	-25	-20	-15	-10	-5	0
INBEX3000L6D	30	06ER399	130	C	39,263.00	50,240.00	62,087.00	74,930.00	88,896.00	104,111.00	120,701.00	138,794.00	158,515.00
				P	14.80	17.10	19.40	21.90	24.50	27.10	29.70	32.50	35.20
				A	30.8	33.3	35.8	38.4	41.1	43.9	46.9	50.1	53.5
			120	C	49,251.00	61,268.00	74,300.00	88,473.00	103,914.00	120,749.00	139,104.00	159,106.00	180,881.00
				P	15.70	17.80	20.00	22.40	24.70	27.20	29.70	32.20	34.80
				A	31.7	34.1	36.4	38.9	41.4	44.0	46.8	49.7	52.9
			110	C	59,422.00	72,430.00	86,599.00	102,055.00	118,924.00	137,333.00	157,406.00	179,271.00	203,053.00
				P	16.40	18.40	20.50	22.60	24.90	27.10	29.40	31.80	34.20
				A	32.4	34.6	36.9	39.1	41.5	43.9	46.4	49.1	52.0
			100	C	69,684.00	83,635.00	98,893.00	115,584.00	133,832.00	153,765.00	175,509.00	199,189.00	224,931.00
				P	16.90	18.70	20.70	22.70	24.70	26.80	28.90	31.10	33.30
				A	32.9	35.0	37.1	39.2	41.3	43.5	45.9	48.3	51.0

INBBX-INBDX-INBEX 0.5,1,2 HP | PLANO GENERAL

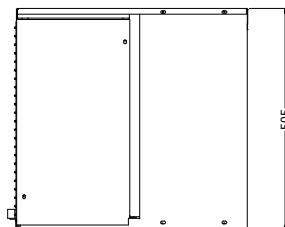
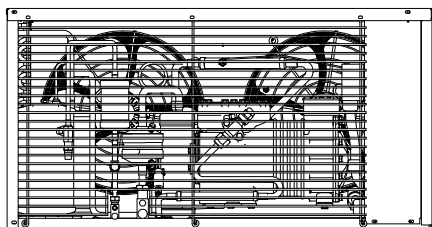
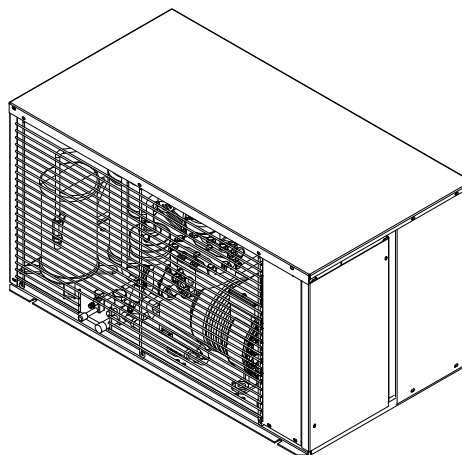
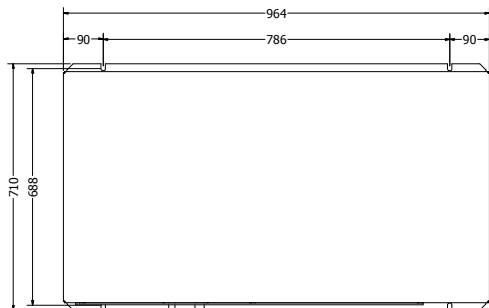

INBBX-INBDX-INBEX 3,4 HP | PLANO GENERAL

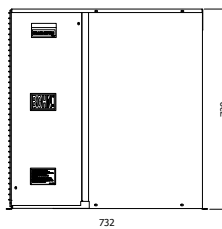
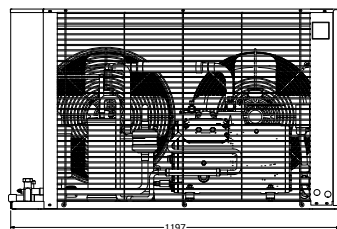
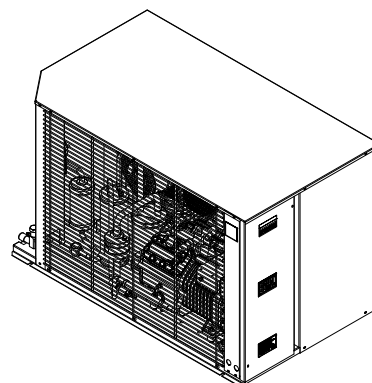
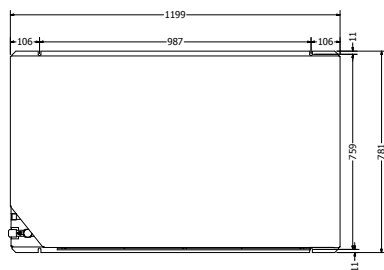

INBEX

PLANO GENERAL

0.5,1,2, 3,4 HP

INBBX-INBDX-INBEX 5,6,7,7.5,9,10 HP | PLANO GENERAL

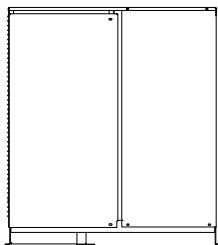
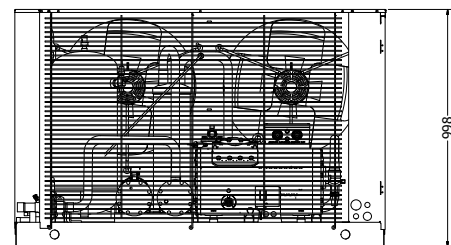
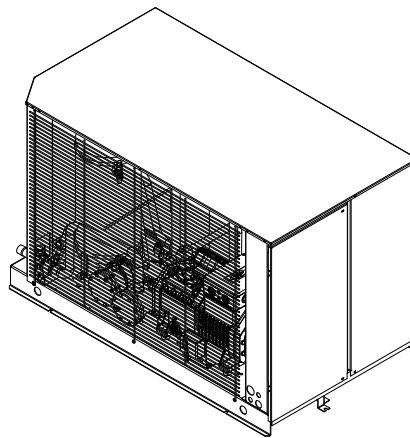
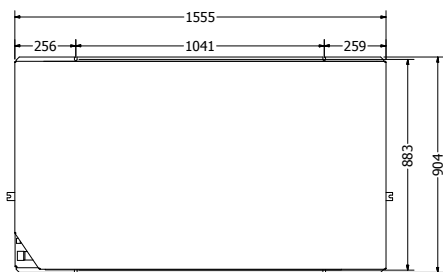

INBBX-INBDX-INBEX 12,14,15,18 HP | PLANO GENERAL

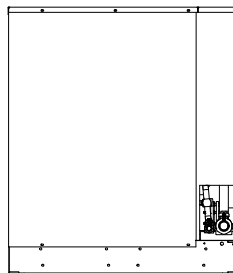
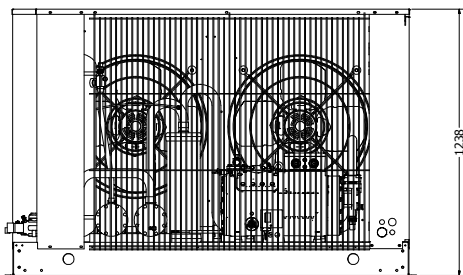
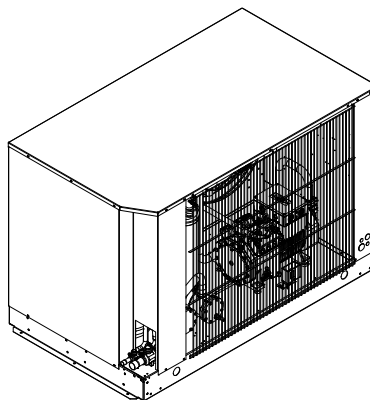
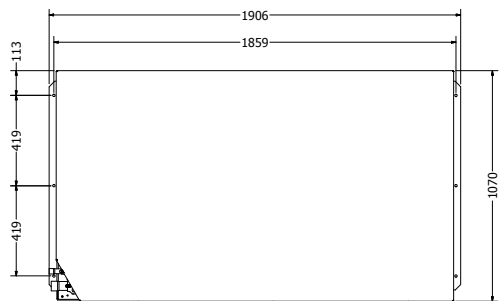

UNIDADES CONDENSADORAS
INBDX, INBBX, INBCX, INBEX

INBBX-INBDX-INBEX 20,22,23,27,28,30,34,44 HP | PLANO GENERAL

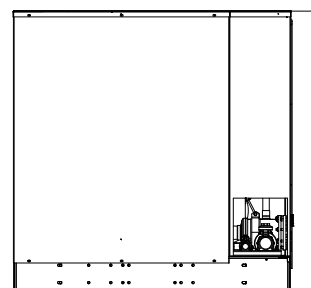
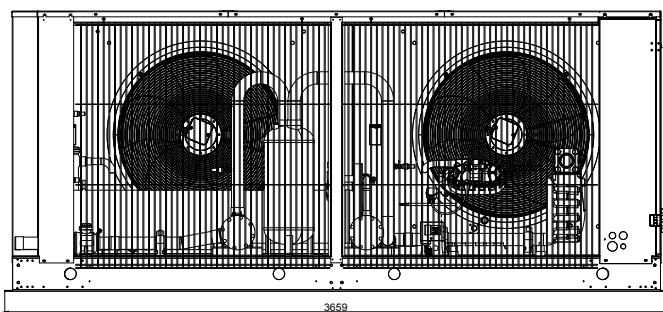
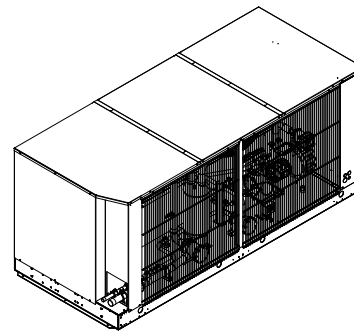
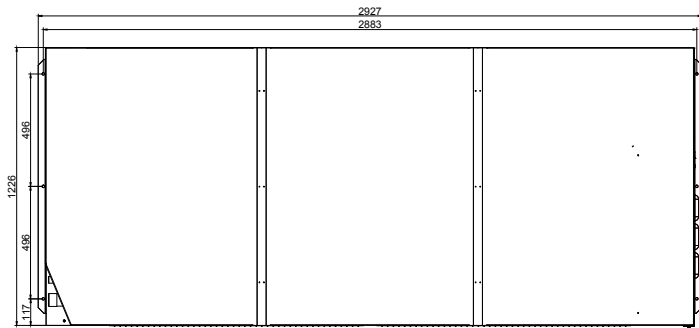

INBBX-INBDX-INBEX 40 HP MEDIA TEMPERATURA | PLANO GENERAL

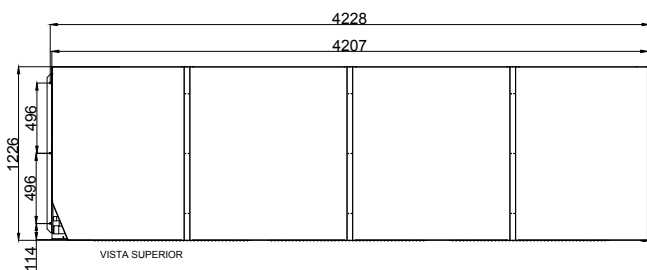

VISTA SUPERIOR

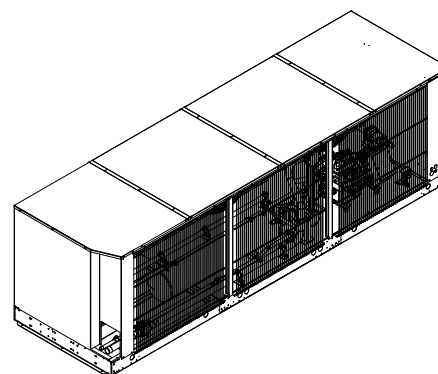

ISOMETRICO SE

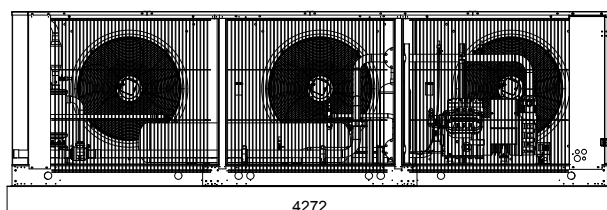

VISTA FRONTAL

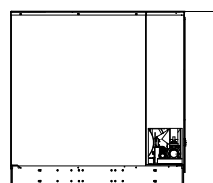

VISTA LATERAL

UNIDAD CONDENSADORA MBBX/MBDX
COMPRESORES SEMIHERMETICOS
DE PISTONES

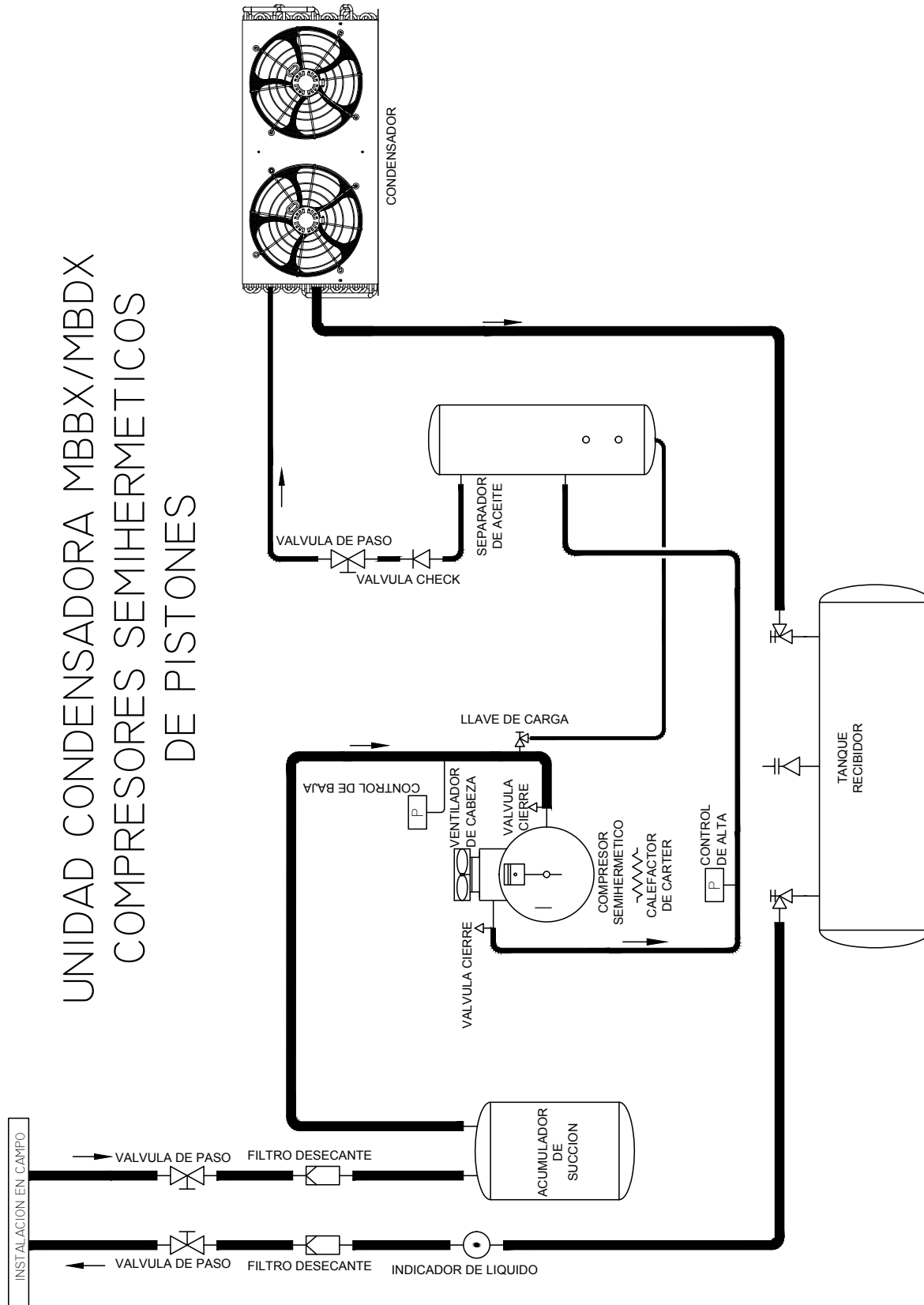

COMPRESOR	DESCARGA	LÍQUIDO	Unidades Condensadoras INBHx			EQUIPO	CONTROL	CHASIS	OPCIONALES
			SUCCIÓN	ACEITE					
Semihermético de pistones	Condensador cobre y aluminio Bohn gold	Filtro desecante para la línea de líquido*	Filtro de succión*	Carga de aceite Poliolester		Gabinete eléctrico de fuerza y control	Tarjeta de control servicemate (desde 5HP)	Base de lamina de acero galvanizado	KIT 2: Válvula Solenoide, Bobina, Punto de conexión, cableado al tablero
Calefactor de Carter	Doble moto-ventilador	Indicador de líquido y humedad	Válvula de paso con acceso a servicio			Contactador para compresor	AlaINBrado con código de color y número.	Lámina galvanizada prepintada a prueba de intemperie	.
Control de presión baja ajustable	Separador de aceite Helicoidal	Tanque recibidor con dispositivo de seguridad	Acumulador de succión			Contactador para ventiladores del condensador (desde 5HP)	Conector a tierra en todos los conductos eléctricos.		
Control de presión alta Fijo	Válvula de paso con acceso a servicio	Válvula de paso con acceso a servicio							
Control diferencial de aceite (en comp. Con bolNBa de aceite)	Válvula Check								
Válvulas de cierre de servicio									
Ventilador y Bracket para enfriamiento de cabeza (Solo para baja temp.)									

INB

Unidad condensadora
INTERCAL

C

Compresor
C: Compresor Bitzer dos Etapas

X

Exterior
X: Exterior Tiro de aire horizontal

Potencia nominal en HP

0500: 5 HP
0800: 8 HP
1200: 12 HP
1600: 16 HP
2000: 20 HP
2500: 25 HP
3000: 30 HP

5000

X

Rango de Aplicación
X: Temp. Extra Baja

6

Refrigerante
6: R-404A/507

C

Voltaje
B: 208-230/1/60
C: 208-230/3/60

Modelo Unidad	H.P.	Compresor	Cant. Comp.	FLA	MCA	MOPD	Voltaje	RLA	LRA	HP	Cantidad	Consumo Motor FLA
INBCX0500X6C	5	S4T-5.2Y-2NU	1	40	47	80	208-230/3/60	28	150	3/4	2	6
INBCX0500X6D	5	S4T-5.2Y-2NU	1	20	23.5	40	460/3/60	14	75	3/4	2	3
INBCX0800X6C	8	S4N-8.2Y-2NU	1	46	54.5	90	208-230/3/60	34	180	3/4	2	6
INBCX0800X6D	8	S4N-8.2Y-2NU	1	21	24.4	40	460/3/60	14.7	90	3/4	2	3
INBCX1200X6C	12	S4G-12.2Y-2NU	1	60	72	120	208-230/3/60	48	252	3/4	2	6
INBCX1200X6D	12	S4G-12.2Y-2NU	1	30	36	60	460/3/60	24	126	3/4	2	3
INBCX1600X6C	16	S6J-16.2Y-2NU	1	76	91.5	150	208-230/3/60	62	294	11/2	2	7
INBCX1600X6D	16	S6J-16.2Y-2NU	1	38	45.8	80	460/3/60	31	147	11/2	2	3.5
INBCX2000X6C	20	S6H-20.2Y-2NU	1	88	106.5	180	208-230/3/60	74	352	11/2	2	7
INBCX2000X6D	20	S6H-20.2Y-2NU	1	44	53.3	90	460/3/60	37	176	11/2	2	3.5
INBCX2500X6C	25	S6G-25.2Y-2NU	1	100	121.5	210	208-230/3/60	86	436	11/2	2	7
INBCX2500X6D	25	S6G-25.2Y-2NU	1	50	60.8	100	460/3/60	43	218	11/2	2	3.5
INBCX3000X6C	30	S6F-30.2Y-2NU	1	92	112	190	208-230/3/60	81.6	490	2	2	5
INBCX3000X6D	30	S6F-30.2Y-2NU	1	57	69.8	120	460/3/60	51	245	2 1/5	2	3

INBCX | ESPECIFICACIONES

Modelo Unidad	Compresor	Kcal/hr		BTU		Kcal/hr		BTU		Recibidor 90%		Ventilador		MCA de la unidad	
		@ 38°C	@ 100°F	@ 43°C	@ 110°F	@ 54°C	@ 130°F	Lbs.	Kgs.	No.	H.P.	208-230/3/60	460/3/60		
INBCX0500X6C	22.54	23	1 1/8	1/2	80	36	191	75.20	107	42.17	124	48.82	490	1078	
INBCX0500X6D	22.54	23	1 1/8	1/2	80	36	191	75.20	107	42.17	124	48.82	490	1078	
INBCX0800X6C	32.17	33	1 1/8	1/2	80	36	191	75.20	107	42.17	124	48.82	505	1111	
INBCX0800X6D	32.17	33	1 1/8	1/2	80	36	191	75.20	107	42.17	124	48.82	505	1111	
INBCX1200X6C	48.65	49	1 3/8	5/8	180	82	191	75.20	107	42.17	124	48.82	535	1177	
INBCX1200X6D	48.65	49	1 3/8	5/8	180	82	191	75.20	107	42.17	124	48.82	535	1177	
INBCX1600X6C	67.02	68	1 3/8	5/8	180	82	293	115.24	123	48.27	124	48.62	920	2024	
INBCX1600X6D	67.02	68	1 3/8	5/8	180	82	293	115.24	123	48.27	124	48.62	920	2024	
INBCX2000X6C	77.9	78	1 3/8	5/8	180	82	293	115.24	123	48.27	124	48.62	935	2057	
INBCX2000X6D	77.9	78	1 3/8	5/8	180	82	293	115.24	123	48.27	124	48.62	935	2057	
INBCX2500X6C	88.99	90	2 1/8	7/8	180	82	293	115.24	123	48.27	124	48.62	970	2134	
INBCX2500X6D	88.99	90	2 1/8	7/8	180	82	293	115.24	123	48.27	124	48.62	970	2134	
INBCX3000X6C	106.69	108	2 1/8	7/8	180	82	293	115.24	123	48.27	124	48.62	1040	2288	
INBCX3000X6D	106.69	108	2 1/8	7/8	180	82	293	115.24	123	48.27	124	48.62	1040	2288	

Modelo	Compresor	H.P	TSC	TSE °F C=Capacidad Btu's/h P=Potencia watts A=Corriente Amps.									
				-60	-55	-50	-45	-40	-35	-30	-25	-20	
				INBCX0500X6C	S4T-5.2Y-2NU	5	125	C	11,343	13,022	14,851	16,840	18,997
P	4,096	4,414	4,734					5,053	5,371	5,687	5,999	6,308	6,613
A	12.9	13.6	14.3					15.0	15.7	16.4	17.2	17.9	18.6
115	C	11,608	13,318				15,181	17,208	19,406	21,783	24,349	27,113	30,082
	P	3,885	4,183				4,482	4,780	5,076	5,370	5,661	5,948	6,229
	A	12.5	13.1				13.8	14.4	15.0	15.7	16.4	17.0	17.7
105	C	11,903	13,645			15,544	17,609	19,849	22,272	24,887	27,703	30,728	
	P	3,688	3,966			4,243	4,519	4,793	5,065	5,333	5,596	5,854	
	A	12.1	12.7			13.2	13.8	14.4	15.0	15.6	16.2	16.8	
95	C	12,212	13,986			15,922	18,027	20,309	22,779	25,444	28,312	31,394	
	P	3,502	3,758			4,013	4,267	4,519	4,767	5,011	5,251	5,485	
	A	11.7	12.3			12.8	13.3	13.8	14.4	14.9	15.4	16.0	
INBCX0800X6C	S4N-8.2Y-2NU	8	125	C	16,196	18,563	21,139	23,936	26,965	30,237	33,765	37,559	41,631
				P	5,864	6,311	6,761	7,214	7,668	8,119	8,567	9,008	9,443
				A	17.5	18.5	19.5	20.6	21.6	22.7	23.8	24.9	26.0
			115	C	16,580	19,003	21,641	24,505	27,606	30,956	34,568	38,451	42,618
				P	5,550	5,975	6,402	6,829	7,256	7,679	8,098	8,509	8,911
				A	16.8	17.7	18.7	19.7	20.7	21.7	22.7	23.7	24.7
		105	C	16,989	19,464	22,160	25,087	28,256	31,681	35,371	39,340	43,597	
			P	5,263	5,662	6,062	6,461	6,858	7,251	7,636	8,014	8,381	
			A	16.2	17.0	17.9	18.8	19.7	20.7	21.6	22.5	23.4	
		95	C	17,409	19,932	22,681	25,667	28,901	32,396	36,162	40,211	44,555	
			P	4,996	5,366	5,736	6,104	6,468	6,827	7,177	7,518	7,846	
			A	15.6	16.4	17.2	18.0	18.9	19.7	20.5	21.3	22.1	
INBCX1200X6C	S4G-12.2Y-2NU	12	125	C	26,865	30,418	34,318	38,546	43,080	47,900	52,988	58,321	63,881
				P	8,827	9,511	10,198	10,883	11,567	12,247	12,922	13,589	14,247
				A	27.8	29.2	30.7	32.2	33.7	35.2	36.8	38.3	39.9
			115	C	27,205	30,995	35,115	39,546	44,268	49,260	54,503	59,975	65,658
				P	8,381	9,019	9,659	10,298	10,936	11,569	12,198	12,818	13,430
				A	26.9	28.2	29.5	30.9	32.3	33.7	35.1	36.5	38.0
		105	C	27,833	31,810	36,101	40,687	45,548	50,662	56,011	61,574	67,330	
			P	7,945	8,536	9,129	9,722	10,314	10,901	11,483	12,058	12,624	
			A	26.0	27.2	28.4	29.6	30.9	32.2	33.5	34.8	36.1	
		95	C	28,636	32,751	37,165	41,857	46,807	51,995	57,401	63,004	68,785	
			P	7,522	8,067	8,613	9,160	9,705	10,246	10,782	11,311	11,831	
			A	25.1	26.2	27.3	28.5	29.6	30.8	32.0	33.1	34.3	
INBCX1600X6C	S6J-16.2Y-2NU	16	125	C	38,668	43,739	49,236	55,145	61,453	68,147	75,212	82,635	90,403
				P	12,356	13,290	14,244	15,217	16,208	17,216	18,239	19,277	20,327
				A	35.9	38.0	40.2	42.6	44.9	47.4	49.9	52.4	55.0
			115	C	39,218	44,512	50,224	56,341	62,849	69,734	76,983	84,582	92,518
				P	11,772	12,640	13,528	14,435	15,359	16,300	17,255	18,224	19,206
				A	34.6	36.5	38.6	40.7	42.9	45.1	47.4	49.8	52.2
		105	C	40,102	45,586	51,480	57,771	64,445	71,489	78,888	86,630	94,700	
			P	11,127	11,935	12,762	13,608	14,470	15,349	16,241	17,147	18,065	
			A	33.1	34.9	36.8	38.7	40.8	42.9	45.0	47.2	49.4	
		95	C	41,186	46,826	52,869	59,301	66,108	73,277	80,793	88,644	96,815	
			P	10,451	11,204	11,976	12,766	13,572	14,394	15,229	16,078	16,937	
			A	31.6	33.3	35.0	36.8	38.7	40.6	42.6	44.6	46.7	

INBCX

R404A

208-230V/3F/60HZ

Modelo	Compresor	H.P	TSC	TSE °F C=Capacidad Btu's/h P=Potencia watts A=Corriente Amps.									
				-60	-55	-50	-45	-40	-35	-30	-25	-20	
INBCX2000X6C	S6H-20.2Y-2NU	20	125	C	44,736	50,499	56,773	63,537	70,772	78,456	86,569	95,090	103,999
				P	14,352	15,418	16,510	17,627	18,768	19,932	21,116	22,319	23,541
				A	41.9	44.3	46.8	49.4	52.1	54.9	57.8	60.7	63.8
			115	C	45,279	51,362	57,941	64,994	72,501	80,442	88,795	97,541	106,658
				P	13,632	14,632	15,657	16,706	17,776	18,868	19,979	21,108	22,254
				A	40.3	42.5	44.8	47.3	49.8	52.4	55.0	57.8	60.6
			105	C	46,302	52,648	59,474	66,759	74,482	82,622	91,160	100,073	109,342
				P	12,879	13,815	14,775	15,757	16,760	17,782	18,822	19,879	20,951
				A	38.7	40.7	42.8	45.1	47.4	49.8	52.3	54.8	57.4
95	C	47,615	54,169	61,185	68,645	76,526	84,809	93,473	102,497	111,860			
	P	12,117	12,991	13,888	14,805	15,742	16,696	17,668	18,654	19,655			
	A	37.0	38.9	40.9	42.9	45.1	47.3	49.5	51.9	54.3			
INBCX2500X6C	S6G-25.2Y-2NU	25	125	C	51,093	57,693	64,869	72,595	80,845	89,591	98,809	108,472	118,553
				P	16,441	17,702	18,985	20,287	21,607	22,942	24,291	25,652	27,021
				A	49.0	51.7	54.5	57.4	60.4	63.5	66.7	70.0	73.3
			115	C	51,830	58,790	66,306	74,354	82,906	91,936	101,419	111,327	121,636
				P	15,663	16,831	18,022	19,234	20,465	21,714	22,977	24,254	25,541
				A	47.4	49.8	52.4	55.0	57.8	60.6	63.6	66.6	69.7
			105	C	53,050	60,304	68,096	76,400	85,190	94,439	104,121	114,210	124,679
				P	14,806	15,889	16,997	18,128	19,280	20,450	21,637	22,838	24,052
				A	45.6	47.8	50.2	52.6	55.1	57.8	60.5	63.3	66.2
95	C	54,562	62,045	70,047	78,542	87,504	96,906	106,722	116,926	127,492			
	P	13,901	14,908	15,942	17,001	18,082	19,183	20,302	21,437	22,586			
	A	43.8	45.8	48.0	50.2	52.5	54.9	57.4	60.0	62.7			
INBCX3000X6C	S6F-30.2Y-2NU	30	125	C	60,920	68,655	77,057	86,102	95,762	106,013	116,828	128,181	140,047
				P	19,761	21,220	22,712	24,233	25,782	27,354	28,947	30,558	32,184
				A	59.0	62.3	65.7	69.2	72.9	76.6	80.4	84.3	88.3
			115	C	61,721	69,911	78,754	88,223	98,293	108,939	120,133	131,851	144,066
				P	18,712	20,087	21,492	22,926	24,385	25,866	27,367	28,883	30,413
				A	56.7	59.8	62.9	66.2	69.6	73.1	76.6	80.3	83.9
			105	C	63,162	71,731	80,938	90,757	101,162	112,126	123,624	135,630	148,119
				P	17,673	18,964	20,285	21,632	23,003	24,394	25,802	27,225	28,659
				A	54.5	57.3	60.2	63.3	66.4	69.6	72.9	76.3	79.7
95	C	64,990	73,864	83,360	93,452	104,115	115,323	127,049	139,268	151,954			
	P	16,650	17,859	19,095	20,357	21,640	22,941	24,259	25,589	26,929			
	A	52.3	54.9	57.6	60.4	63.3	66.3	69.3	72.4	75.6			

Modelo	Compresor	H.P	TSC	TSE °F °C=Capacidad Btu's/h P=Potencia watts A=Corriente Amps.									
				-60	-55	-50	-45	-40	-35	-30	-25	-20	
INBCX0500X6D	S4T-5.2Y-2NU	5	125	C	11,343	13,022	14,851	16,840	18,997	21,330	23,848	26,560	29,475
				P	4,096	4,414	4,734	5,053	5,371	5,687	5,999	6,308	6,613
				A	6.5	6.8	7.1	7.5	7.9	8.2	8.6	8.9	9.3
			115	C	11,608	13,318	15,181	17,208	19,406	21,783	24,349	27,113	30,082
				P	3,885	4,183	4,482	4,780	5,076	5,370	5,661	5,948	6,229
				A	6.3	6.6	6.9	7.2	7.5	7.9	8.2	8.5	8.9
		105	C	11,903	13,645	15,544	17,609	19,849	22,272	24,887	27,703	30,728	
			P	3,688	3,966	4,243	4,519	4,793	5,065	5,333	5,596	5,854	
			A	6.1	6.3	6.6	6.9	7.2	7.5	7.8	8.1	8.4	
		95	C	12,212	13,986	15,922	18,027	20,309	22,779	25,444	28,312	31,394	
			P	3,502	3,758	4,013	4,267	4,519	4,767	5,011	5,251	5,485	
			A	5.9	6.1	6.4	6.6	6.9	7.2	7.5	7.7	8.0	
INBCX0800X6D	S4N-8.2Y-2NU	8	125	C	16,196	18,563	21,139	23,936	26,965	30,237	33,765	37,559	41,631
				P	5,864	6,311	6,761	7,214	7,668	8,119	8,567	9,008	9,443
				A	8.7	9.2	9.8	10.3	10.8	11.4	11.9	12.4	13.0
			115	C	16,580	19,003	21,641	24,505	27,606	30,956	34,568	38,451	42,618
				P	5,550	5,975	6,402	6,829	7,256	7,679	8,098	8,509	8,911
				A	8.4	8.9	9.3	9.8	10.3	10.8	11.3	11.8	12.3
		105	C	16,989	19,464	22,160	25,087	28,256	31,681	35,371	39,340	43,597	
			P	5,263	5,662	6,062	6,461	6,858	7,251	7,636	8,014	8,381	
			A	8.1	8.5	9.0	9.4	9.9	10.3	10.8	11.2	11.7	
		95	C	17,409	19,932	22,681	25,667	28,901	32,396	36,162	40,211	44,555	
			P	4,996	5,366	5,736	6,104	6,468	6,827	7,177	7,518	7,846	
			A	7.8	8.2	8.6	9.0	9.4	9.8	10.2	10.7	11.0	
INBCX1200X6D	S4G-12.2Y-2NU	12	125	C	26,865	30,418	34,318	38,546	43,080	47,900	52,988	58,321	63,881
				P	8,827	9,511	10,198	10,883	11,567	12,247	12,922	13,589	14,247
				A	13.9	14.6	15.3	16.1	16.8	17.6	18.4	19.2	20.0
			115	C	27,205	30,995	35,115	39,546	44,268	49,260	54,503	59,975	65,658
				P	8,381	9,019	9,659	10,298	10,936	11,569	12,198	12,818	13,430
				A	13.4	14.1	14.8	15.4	16.1	16.8	17.6	18.3	19.0
		105	C	27,833	31,810	36,101	40,687	45,548	50,662	56,011	61,574	67,330	
			P	7,945	8,536	9,129	9,722	10,314	10,901	11,483	12,058	12,624	
			A	13.0	13.6	14.2	14.8	15.5	16.1	16.8	17.4	18.1	
		95	C	28,636	32,751	37,165	41,857	46,807	51,995	57,401	63,004	68,785	
			P	7,522	8,067	8,613	9,160	9,705	10,246	10,782	11,311	11,831	
			A	12.6	13.1	13.7	14.2	14.8	15.4	16.0	16.6	17.1	
INBCX1600X6D	S6J-16.2Y-2NU	16	125	C	38,668	43,739	49,236	55,145	61,453	68,147	75,212	82,635	90,403
				P	12,356	13,290	14,244	15,217	16,208	17,216	18,239	19,277	20,327
				A	17.9	19.0	20.1	21.3	22.5	23.7	24.9	26.2	27.5
			115	C	39,218	44,512	50,224	56,341	62,849	69,734	76,983	84,582	92,518
				P	11,772	12,640	13,528	14,435	15,359	16,300	17,255	18,224	19,206
				A	17.3	18.3	19.3	20.3	21.4	22.6	23.7	24.9	26.1
		105	C	40,102	45,586	51,480	57,771	64,445	71,489	78,888	86,630	94,700	
			P	11,127	11,935	12,762	13,608	14,470	15,349	16,241	17,147	18,065	
			A	16.6	17.5	18.4	19.4	20.4	21.4	22.5	23.6	24.7	
		95	C	41,186	46,826	52,869	59,301	66,108	73,277	80,793	88,644	96,815	
			P	10,451	11,204	11,976	12,766	13,572	14,394	15,229	16,078	16,937	
			A	15.8	16.6	17.5	18.4	19.3	20.3	21.3	22.3	23.3	

Modelo	Compresor	H.P	TSC	TSE °F °C=Capacidad Btu's/h P=Potencia watts A=Corriente Amps.									
				-60	-55	-50	-45	-40	-35	-30	-25	-20	
INBCX2000X6D	S6H-20.2Y-2NU	20	125	C	44,736	50,499	56,773	63,537	70,772	78,456	86,569	95,090	103,999
				P	14,352	15,418	16,510	17,627	18,768	19,932	21,116	22,319	23,541
				A	20.9	22.2	23.4	24.7	26.1	27.5	28.9	30.4	31.9
			115	C	45,279	51,362	57,941	64,994	72,501	80,442	88,795	97,541	106,658
				P	13,632	14,632	15,657	16,706	17,776	18,868	19,979	21,108	22,254
				A	20.1	21.3	22.4	23.6	24.9	26.2	27.5	28.9	30.3
		105	C	46,302	52,648	59,474	66,759	74,482	82,622	91,160	100,073	109,342	
			P	12,879	13,815	14,775	15,757	16,760	17,782	18,822	19,879	20,951	
			A	19.3	20.4	21.4	22.5	23.7	24.9	26.1	27.4	28.7	
		95	C	47,615	54,169	61,185	68,645	76,526	84,809	93,473	102,497	111,860	
			P	12,117	12,991	13,888	14,805	15,742	16,696	17,668	18,654	19,655	
			A	18.5	19.4	20.4	21.5	22.5	23.6	24.8	25.9	27.1	
INBCX2500X6D	S6G-25.2Y-2NU	25	125	C	51,093	57,693	64,869	72,595	80,845	89,591	98,809	108,472	118,553
				P	16,441	17,702	18,985	20,287	21,607	22,942	24,291	25,652	27,021
				A	24.5	25.8	27.2	28.7	30.2	31.7	33.3	35.0	36.7
			115	C	51,830	58,790	66,306	74,354	82,906	91,936	101,419	111,327	121,636
				P	15,663	16,831	18,022	19,234	20,465	21,714	22,977	24,254	25,541
				A	23.7	24.9	26.2	27.5	28.9	30.3	31.8	33.3	34.9
		105	C	53,050	60,304	68,096	76,400	85,190	94,439	104,121	114,210	124,679	
			P	14,806	15,889	16,997	18,128	19,280	20,450	21,637	22,838	24,052	
			A	22.8	23.9	25.1	26.3	27.6	28.9	30.2	31.6	33.1	
		95	C	54,562	62,045	70,047	78,542	87,504	96,906	106,722	116,926	127,492	
			P	13,901	14,908	15,942	17,001	18,082	19,183	20,302	21,437	22,586	
			A	21.9	22.9	24.0	25.1	26.3	27.5	28.7	30.0	31.4	
INBCX3000X6D	S6F-30.2Y-2NU	30	125	C	60,920	68,655	77,057	86,102	95,762	106,013	116,828	128,181	140,047
				P	19,761	21,220	22,712	24,233	25,782	27,354	28,947	30,558	32,184
				A	29.5	31.2	32.9	34.6	36.4	38.3	40.2	42.2	44.1
			115	C	61,721	69,911	78,754	88,223	98,293	108,939	120,133	131,851	144,066
				P	18,712	20,087	21,492	22,926	24,385	25,866	27,367	28,883	30,413
				A	28.4	29.9	31.5	33.1	34.8	36.5	38.3	40.1	42.0
		105	C	63,162	71,731	80,938	90,757	101,162	112,126	123,624	135,630	148,119	
			P	17,673	18,964	20,285	21,632	23,003	24,394	25,802	27,225	28,659	
			A	27.2	28.6	30.1	31.6	33.2	34.8	36.5	38.1	39.9	
		95	C	64,990	73,864	83,360	93,452	104,115	115,323	127,049	139,268	151,954	
			P	16,650	17,859	19,095	20,357	21,640	22,941	24,259	25,589	26,929	
			A	26.2	27.4	28.8	30.2	31.6	33.1	34.7	36.2	37.8	

INBCX 5,8,12 HP | PLANO GENERAL

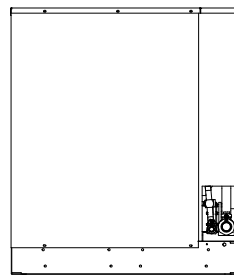
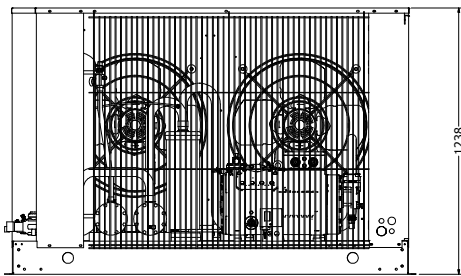
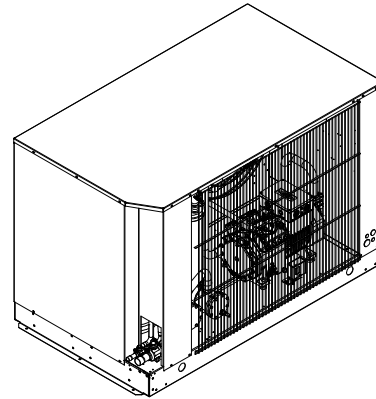
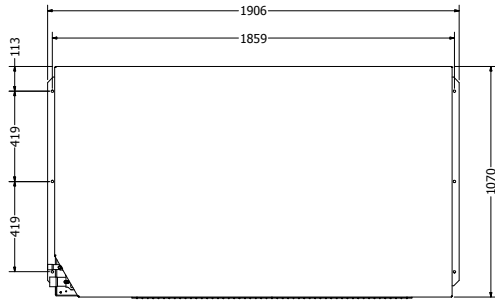

INBCX 5,8,12 HP | PLANO GENERAL

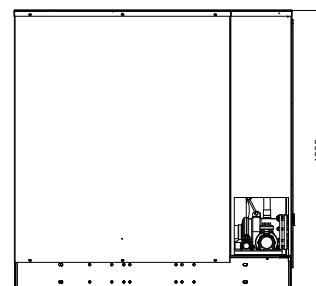
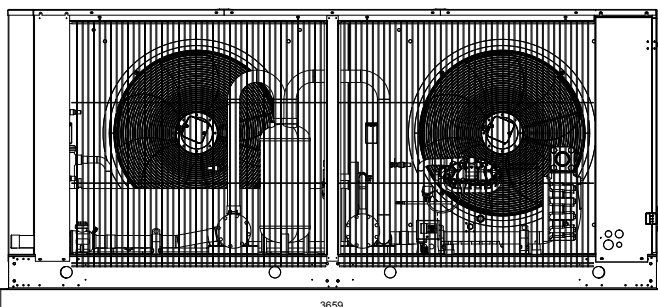
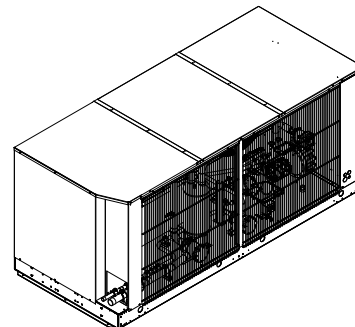
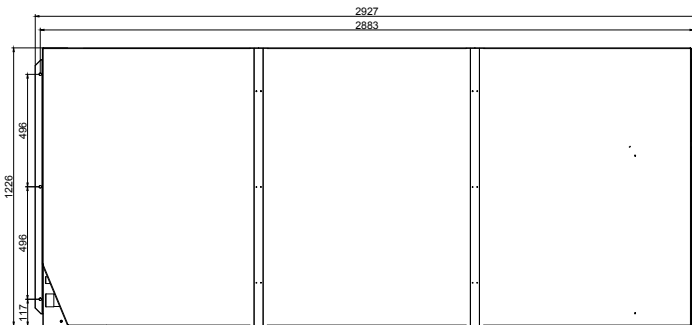

UNIDADES CONDENSADORAS
INBDX, INBBX, INBCX, INBEX



DIAGRAMA DE FLUJO

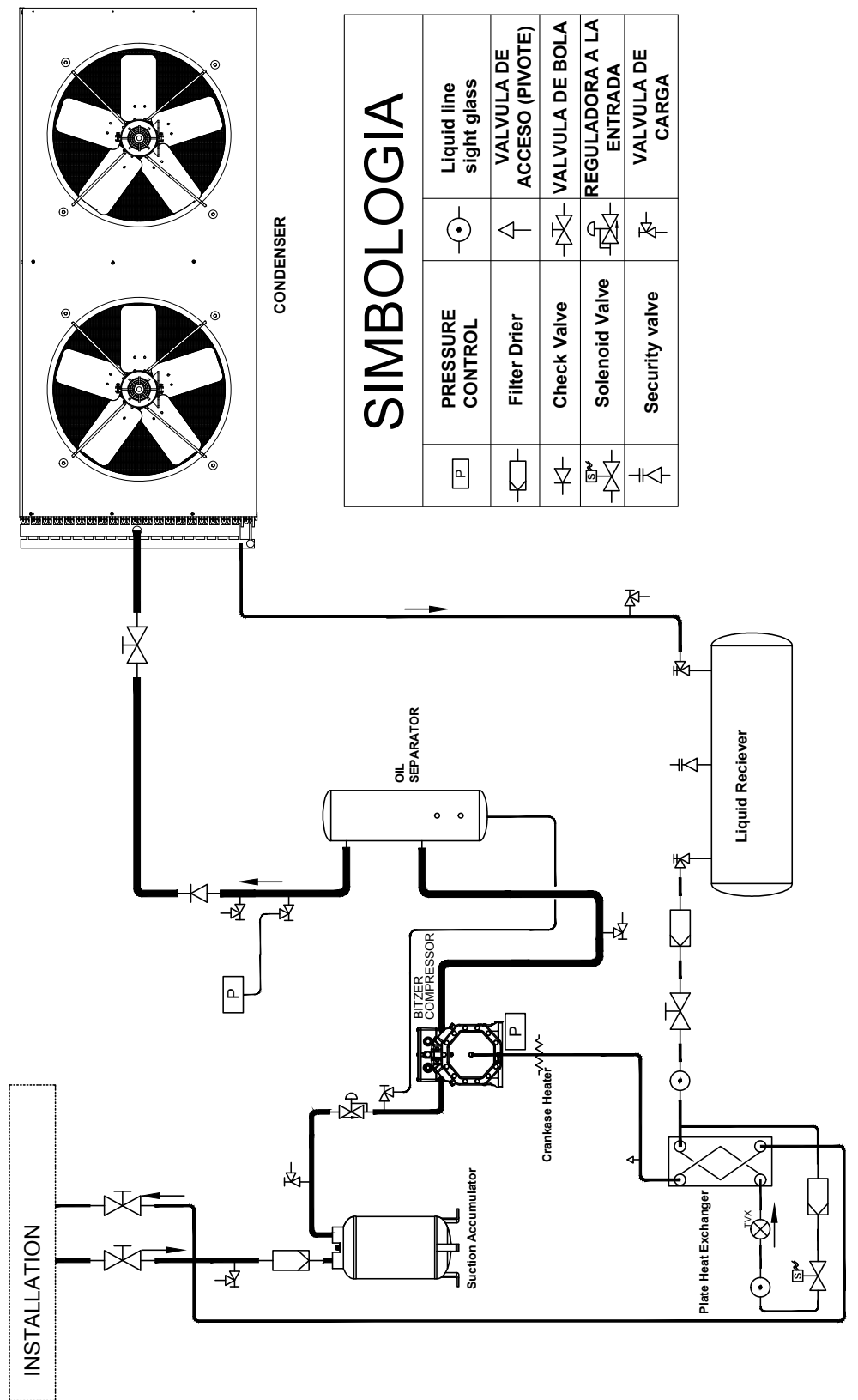



Planta Chile

San Ignacio 051, Quilicura
Santiago Chile
+562 2714 0900

Planta Querétaro

Acceso II, Calle 2 No. 48
Parque Industrial Benito Juárez
Querétaro, Qro. C.P. 76120
Tel: +52 442 296 4500
Tel: sin costo 01 800 926 20 46

Planta Monterrey

Parque Industrial Finsa Santa Catarina
Carretera a García Km. 3.0
Santa Catarina, N.L.
Tel: +52 55 5000 8505

Planta Mérida

Calle 19 No. 418
Ampliación Ciudad Industrial
C.P. 97390
Umán Yucatán,
Tel: +52 999 946 3483

Visita www.intercal.cl

BC-062, Publicado MAYO 2024, BC-062-C

BOHN se reserva el derecho de hacer cambios en sus especificaciones en cualquier momento, sin previo aviso y sin ninguna responsabilidad con los compradores, propietarios del equipo que previamente se les ha vendido.
Rev 2.0